

Electronic Remote Temperature Sensors
General Instructions

APPLICATION

Electronic thermistor sensing of temperature at remote room locations, ducts, liquid lines, tanks, outdoor air, etc. for microprocessor based energy management systems.

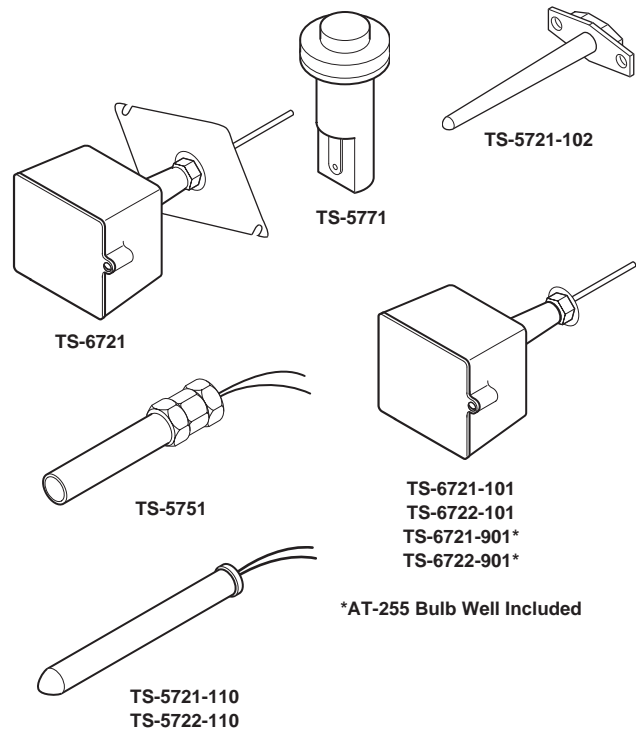

SPECIFICATIONS

Sensing Element: Thermistor resistance, 10,000 ohms or 30,000 ohms (TS-6722-xxx series only) at 77°F (25°C).

32 to 158 F° (0 to 70 C°).

Error ± 0.36 F° (0.2 C°) maximum.

Drift/Year 0.045 F° (0.025 C°) maximum.

Over Operating Temperature Limits.

Error ± 0.76 F° (0.42 C°) maximum except
± 0.36 F° (0.2 C°) maximum for TS-5771

Drift/Year 0.09 F° (0.05 C°) maximum

Nominal Resistance Values. See Table 3.

See Tables 1 through 3 for additional specifications.

ACCESSORIES

AT-211	Sun shield.
AT-215	Stainless steel bulb well for TS-6721.
AT-225	Stainless steel bulb well for TS-6721-101 and TS-6722-101.
AT-226	High pressure brass well.
M-500	Temperature conductive grease.

Table-1 Specifications.

Part Number	Description	Mounting Connection	Dimensions in. (mm)		Wiring Connections
			Element	Wiring Enclosure	
TS-6721	Duct/ Immersion ^a	Flange, 1/4-in. NPT ^a	1/4 (6) dia. x 8 (203) lg.	2-7/8 H x 2-3/8 W x 1-1/2 D (73 x 60 x 30) with 2-1/2 (64) Extension to Element. 1/2-in Knockout (top).	12 in. (305 mm) Brown Pigtail Leads
TS-6721-101 TS-6722-101	Immersion ^b	1/4-in. NPT Nut ^b	1/4 (6) dia. x 4 (102) lg.		
TS-6721-901 TS-6722-901	Immersion	1/4-in. NPT Nut ^c	1/4 (6) dia. x 4 (102) lg.		
TS-5721-110 TS-5722-110	Strap-On	Nylon Wire Tie ^d	1/4 (6) dia. x 2-1/4 (57) lg.	None	
TS-5721-102	Duct	Mounting Flange	5/16 (8) dia. x 7-3/4 (197) lg.	None (can be mounted in a NEMA Standard 5-16-1984 handy box)	1/4-in. Spade Connections (2 female connectors provided)
TS-5751	Outdoor	1/2-in. Conduit	1-1/8 (29) dia. x 5 (127) lg	None	3 ft. (0.9 m) Brown Pigtail Leads
TS-5771	Unitary ^e	17/32-in. (13.5 mm) dia. Mtg. Hole ^e	3/4 (19) dia. x 1-1/4 (32) lg.	None	1/4-in. Spade Connections (2 female connectors provided)

^a Immersion requires AT-215 or AT-226 bulb well.

^b Immersion requires AT-225 bulb well.

^c AT -225 bulb well included.

^d Factory supplied 2-1/2 x 2 in. (64 x 51 mm) foam insulation tape and 30 in. (762 mm) nylon wire tie for 1-1/2 thru 8 in. (38 thru 203 mm) diameter pipes.

^e For mounting through fan coil of unit ventilator cabinet or similar application. Ambient humidity limits, 5 to 95% RH, non-condensing.

Table-2 Ambient Temperature Limits °F (°C).

Part Number	Shipping & Storage	Operating
TS-6721 TS-6721-101 TS-5721-110 TS-6721-901	-40 to 250 (-40 to 121)	-40 to 250 (-40 to 121)
TS-5721-102	-40 to 160 (-40 to 71)	-40 to 140 (-40 to 60)
TS-6722-101 TS-5722-110 TS-6722-901	-40 to 250 (-40 to 121)	85 to 250 (29 to 121)
TS-5751	-40 to 220 (-40 to 104)	-40 to 140 (-40 to 60)
TS-5771	-40 to 160 (-40 to 71)	40 to 140 (4 to 60)

Table-3 Temperature VS. Resistance.

Temperature °F (°C)	Nominal Resistance Values (in 1000 Ohms)	
	TS-6721 TS-6721-101 TS-5721-102 TS-5721-110 TS-6721-901 TS-5751 TS-5771	TS-6722-101 TS-5722-110 TS-6722-901
-40 (-40)	239.8	
-22 (-30)	135.2	
- 4 (-20)	78.91	
14 (-10)	47.54	
32 (0)	29.94	
50 (10)	18.79	
68 (20)	12.26	
77 (25)	10.00	30.00
86 (30)	8.194	24.582
104 (40)	5.592	16.776
122 (50)	3.893	11.679
140 (60)	2.760	8.280
158 (70)	1.990	5.970
176 (80)	1.458	4.734
194 (90)	1.084	3.252
212 (100)	0.816	2.448
230 (110)	0.623	1.869
248 (120)	0.482	1.446

INSTALLATION

Inspection

Visually inspect the carton for damage. If damaged, notify the appropriate carrier immediately. If undamaged, open the carton and visually inspect the device for obvious defects. Return damaged or defective products.

Requirements

- Wiring diagrams
- Tools (not provided):
 - DVM (digital volt/ohm meter)
 - Appropriate screwdriver for mounting screws and terminal connections
 - Appropriate drill and drill bit for mounting screws
- Appropriate accessories
- Mounting screws two #10 x 3/4" sheet metal, provided with TS-6721 and TS-5721-102

Precautions

▼CAUTION

1. Installer must be a qualified, experienced technician.
2. Make all connections in accordance with the wiring diagram, and in accordance with national and local electrical codes. Use copper conductors only.

Mounting

▼CAUTION

Avoid locations where excessive vibration, moisture, corrosive fumes or vapors are present.

TS-6721 Duct/Immersion Sensors

Duct

Note: Hand tighten only - do not overtighten.

1. Determine the sensor mounting location on the duct (predetermine the knockout hole location for routing of conduit). The sensing element is located within 1 inch of the end of the sensing probe, and it should be in the air stream at a location that is typical of the temperature requiring sensing. Approximately 3" of length adjustment is available.
2. Use the mounting flange supplied as a template (or refer to Figure 1 for duct mounting dimensions) for the mounting hole location.
3. Mount the sensor to the duct using the two #10 x 3/4-in. sheet metal screws provided.

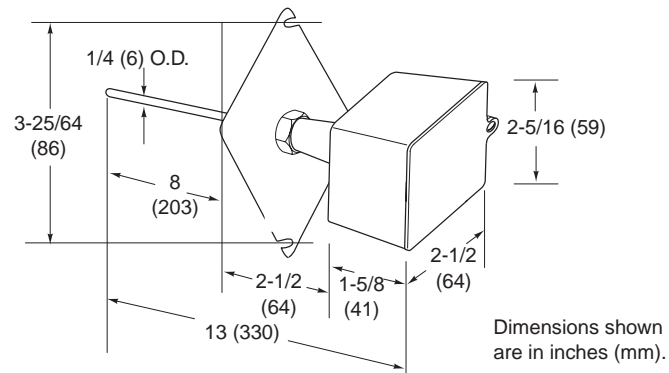

Figure-1 TS-6721 Mounting Dimensions.

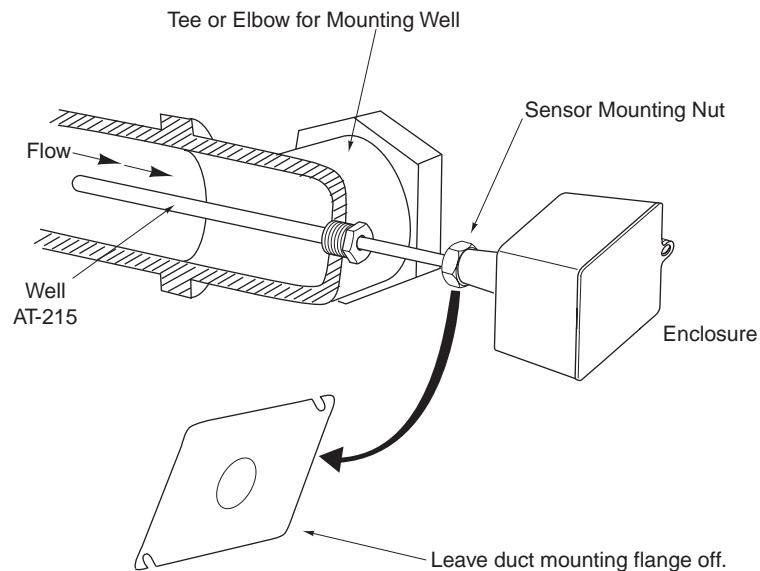

Figure-2 TS-6721 Immersion Mounting.

Immersion (Requires AT-215 Bulb Well)

Thread the sensor into AT-215 bulb well that has been installed in a liquid line or tank.

Note: The AT-215 bulb well should be filled with a temperature conductive grease prior to element insertion, for optimum medium temperature sensing.

TS-5721-102 Duct Sensors

1. Determine the sensor mounting location on the duct. The sensing element is located within 1 inch (25 mm) of the end of the sensing probe, and it should be in the air stream at a location that is typical of the temperature requiring sensing.
2. Use the mounting flange supplied as a template (or refer to Figure 2 for duct mounting dimensions) for the mounting hole location.

3. Mount the sensor to the duct using two #10 x 3/4-in. sheet metal screws provided.

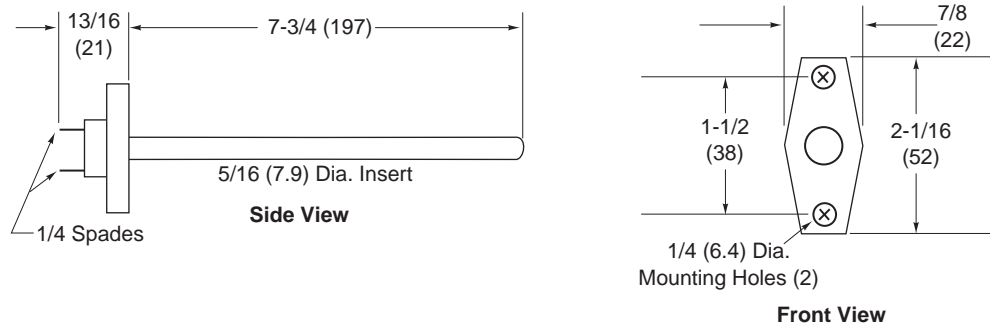

Dimensions shown are in inches (mm).

Figure-3 TS-5721-102 Mounting Dimensions.

TS-672X-101 and TS-672X-901 Immersion Sensors

TS-6721-101 requires AT-225 bulb well to be purchased separately (see Figure-4). Thread the sensor into AT 225 bulb well that has been installed in a liquid line or tank.

Note: The AT-225 bulb well should be filled with a temperature conductive grease prior to element insertion, for optimum medium temperature sensing.

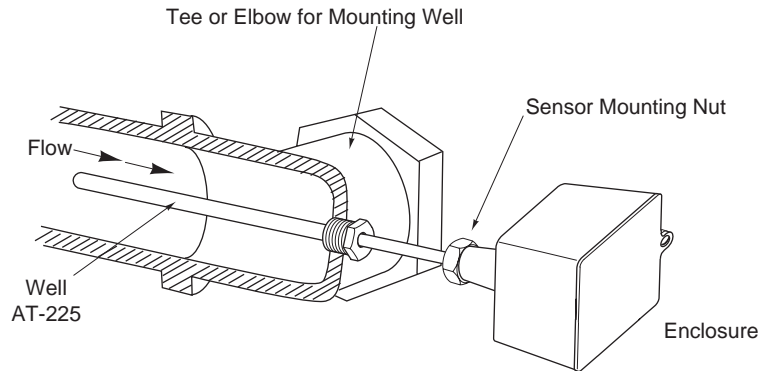

Figure-4 TS-672x-101 and TX-672x-901 Immersion Mounting.

TS-5721-110 and TS-5722-110 Strap-On Sensors

Foam insulation tape should be taped over the sensor. Extend insulation beyond the ends of the sensor.

Secure sensor and foam insulation tape to pipe with wire tie (factory supplied) or metal hose clamp (not included). See Figure-5.

CAUTION

Do not tighten clamp or wire tie to the point of distorting the sensor. Overtightening fasteners will cause a shift in sensed temperature.

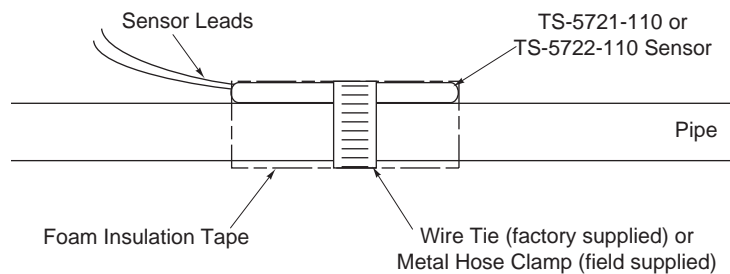

Figure-5 Typical TS-572x-110 Strap-On Sensor Installation.

TS-5751 OUTDOOR AIR SENSOR

Mount sensor to waterproof conduit box using the 1/2-in. conduit connection (see Figure-6 and Figure-7).

Use sun shield if required by application (see Figure-8).

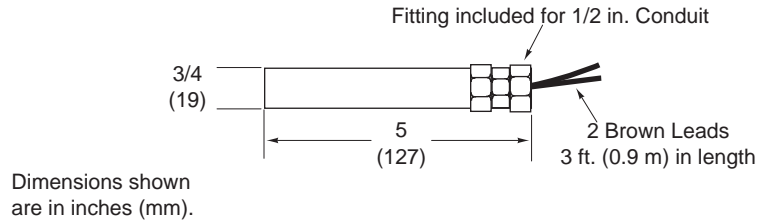

Figure-6 TS-5751 Mounting Dimensions.

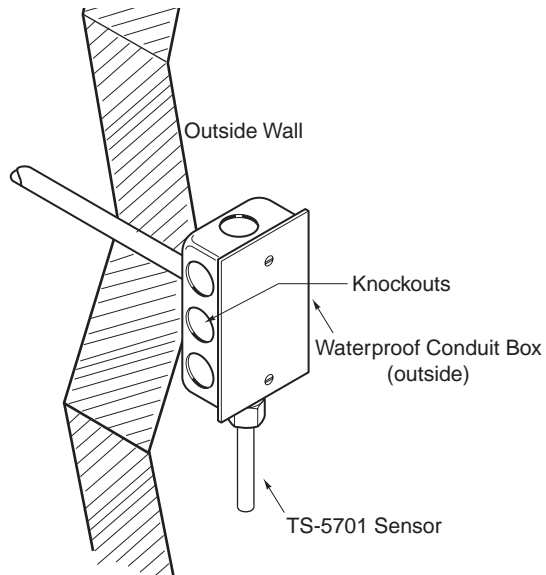

Figure-7 TS-5751 Typical Mounting.

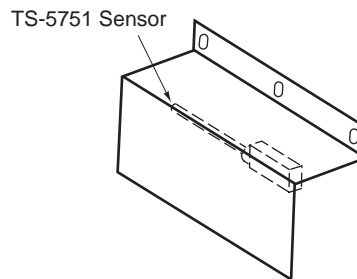
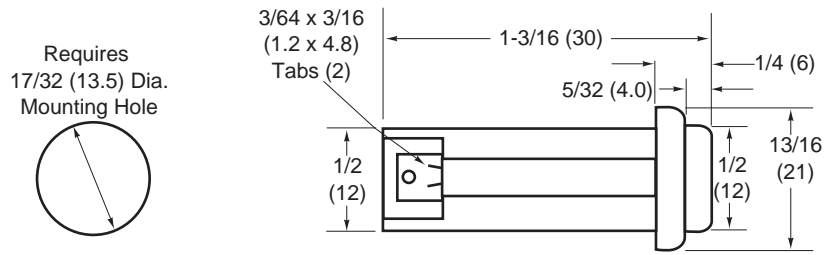

Figure-8 TS-5751 Mounted with Shield.

TS-5771 Unitary Sensor

1. Determine the sensor mounting location.
2. Drill 17/32-in. (13.5 mm) diameter mounting hole.
3. Insert gasket to base of sensor "button".
4. Insert sensor with gasket into mounting hole.
5. Secure sensor to mounting flange by inserting Tinnerman nut over back of sensor.
6. Two crimp wire receptacles are provided for spade terminal connection to field wiring. See Figure-9.



Dimensions shown are in inches (mm).

Figure-9 TS-5771 Mounting Dimensions.

Mounting Duct Sensor Using Existing Mounting Plate

Table-4 Applicable Models.

New Part Number	Old Part Number
TS-6721	TS-5721
TS-6721-101	TS-5721-101
TS-6721-901	TS-5721-901
TS-6722-101	TS-5722-101
TS-6722-901	TS-5722-901

When a duct sensor is being replaced at a location where an existing mounting hole size exceeds the coverage of the adaptor flange, use the existing mounting plate as follows:

1. Remove the existing unit from the duct. Note location of the unit's conduit hole.
2. Remove (and set aside for later use) the conduit nut securing the mounting plate to the sensor.
3. Remove the mounting plate from the old sensor.
4. Place the mounting plate on the new sensor and secure with the conduit nut removed from the old sensor. Do not include the plastic adaptor flange.
5. When mounting the sensor to the duct, be sure the conduit hole is located appropriately.

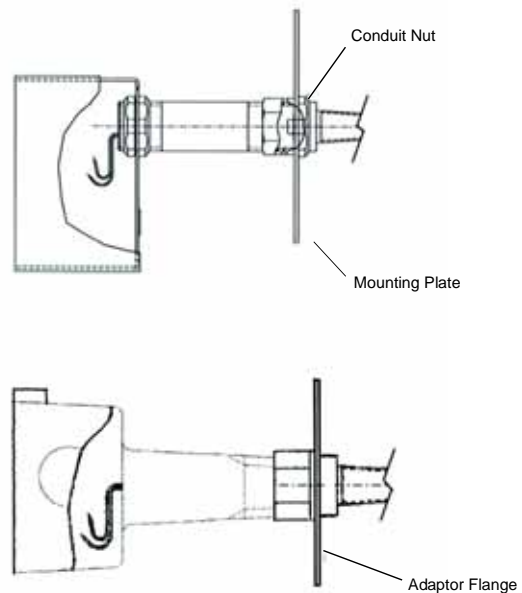

Figure-10 Mounting Duct Sensor Using Existing Mounting Plate.

WIRING

Two conductor twisted wires (six turns per foot). Class II, low voltage, are suitable for the sensor leads except as stated below.

▼CAUTION

Shielded cable must be used when it is necessary to install the sensor lead in the same conduit with power wiring, or when it is known that high RF/EMI generating devices are near. System Ground the shield per the controller manufacturer's specifications.

It is generally advisable to use flexible conduit to connect enclosure to rigid conduit.

Restrict element lead to shortest length practical (see Table 4).

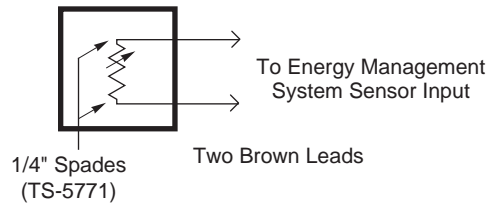

Figure-11 Sensor Connections.

Table-5 Sensor Wiring Lengths.

Wire Gauge	Length of Run ft. (m)
	Sensor to Energy Management Systems
22	150 (46)
18	1000 (305)
16	2250 (686)
14	4000 (1219)

MAINTENANCE

Regular maintenance of the total system is needed to assure sustained optimum performance. Sensors should be periodically inspected for dirt or blockage of air over the elements.

FIELD REPAIR

These sensors are not field repairable. Replace the sensor with a functional unit.