

**Floating Neutral Center Electric
Room Thermostat
General Instructions**

APPLICATION

Room thermostat for floating control of one MF-1233 series actuator.

SPECIFICATIONS

Anticipation: Heating and cooling, factory installed resistors.

Setpoint Dial Range*: 55 to 85°F or 13 to 29°C.

Sensing Element: Bimetal.

Control Span: 4°F (2°C).

Electrical Switch: SPDT floating center off.

Ratings: 0.160 FLA @ 24 Vac maximum.

Connections: Color coded 6" leads.

Cover: Beige plastic as standard.

Mounting: Flush or surface 2 x 4 switch box or directly to wall.

Dimensions: 4-3/8" high x 2-7/8" wide x 1-5/8" deep (111 mm x 73 mm x 41 mm).

*Dial stop pins included to limit setpoint range.

Standard

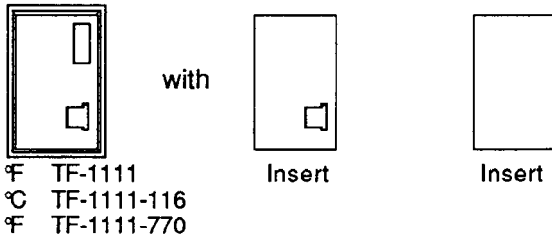

Options (for quantities of 24 or more each part number)

Add "dash-number" (-XXX) suffix to base part number for desired option.

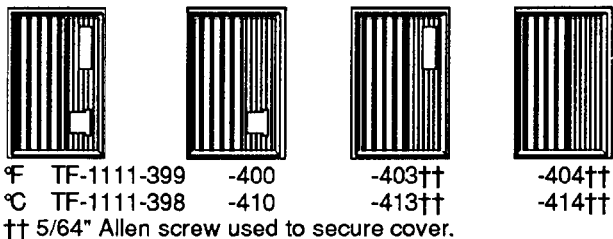
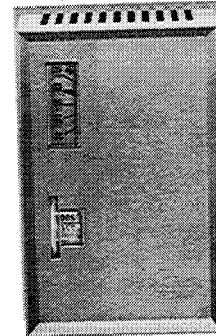

Table-1 SPECIFICATIONS.

Part Number	Company Identification	Setpoint Dial Range*
TF-1111	TAC	55 to 85°F
TF-1111-116	TAC	13 to 29°C
TF-1111-770	Robertshaw	55 to 85°F

* Dial stop pins included to limit setpoint range.



TF-1111

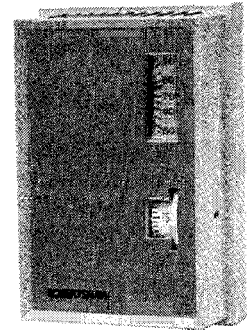

TF-1111-770

ACCESSORIES

- AT-82 Series Digital thermometer cover kit
- AT-101 Lock cover kit
- AT-104 Dial stop pins (Note: pins included with each unit)
- AT-504 Plaster hole cover kit (small)
- AT-505 Surface mounting base
- AT-546 Auxiliary mounting plate
- AT-602 Selector switch sub-base DP4T
- AT-603 Selector switch sub-base one DP4T, one DPDT
- AT-1103 Wire guard
- AT-1104 Cast aluminum guard
- AT-1105 Plastic guard
- AT-1155 Plastic guard
- AT-1165 Plastic guard
- PKG-1093 Digital thermometer battery replacement kit
- TOOL-13 Contact burnishing tool

PRE-INSTALLATION

Inspection

Inspect the carton for damage. If damaged, notify the appropriate carrier immediately. If undamaged, open the carton and inspect the device for obvious damage due to shipping. Return damaged products.

Required Installation Items

- Wiring diagram
- Tools (not provided):
 - Volt-ohm meter
 - Room temperature thermometer in °F
 - Appropriate screwdriver(s) for cover, mounting screws and 1/8" blade screwdriver for calibration

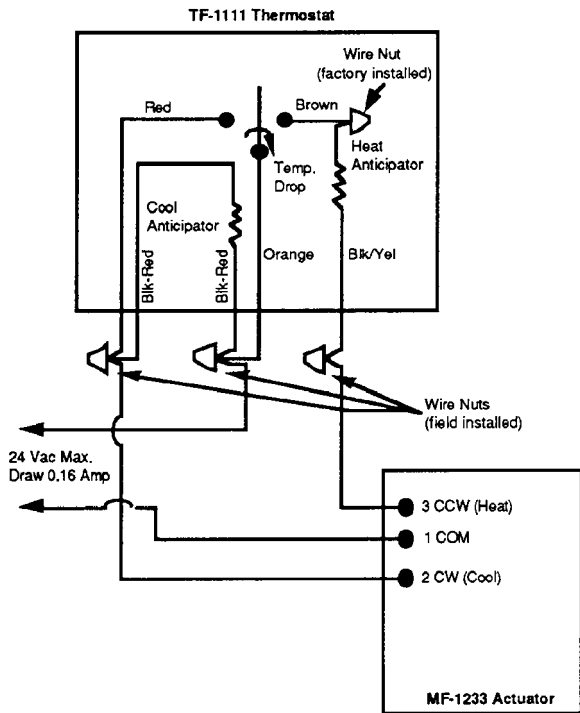

Figure-1 Switch Action and Typical Wiring.

Caution:

Installer must be a qualified, experienced technician.

Disconnect power supply before installation to prevent electrical shock and equipment damage.

Make all connections in accordance with the electrical wiring diagrams, and in accordance with national and local codes. Use copper conductors only.

Do not exceed rating of the device.

Warning:

Do not locate the thermostat where there is a danger of electrocution (i.e., shower rooms).

Wire thermostat in series with the control circuit so that safety devices are maintained.

INSTALLATION

Thermostats require upright mounting on a properly flat vertical surface. Locate the thermostat where it will be exposed to unrestricted circulation of air which represents the average temperature of the controlled space. The minimum recommended air velocity over the thermostat is 10 feet per minute.

Caution: Do not locate thermostat near sources of heat or cold such as lamps, motors, sunlight or concealed ducts or pipes.

The thermostat is designed for service in any normally encountered human environment. Avoid locations where excessive moisture, corrosive fumes or vibrations are present. NEMA Type 1 covers are intended for indoor use primarily to provide a degree of protection against contact with the enclosed device.

Procedure

1. Pull all wires. (Use copper wire only).
2. Make electrical connections to thermostat.
3. Remove thermostat cover by loosening cover screw and fasten thermostat to switch box with screws provided or to wall (obtain fasteners locally). See Figure 2.

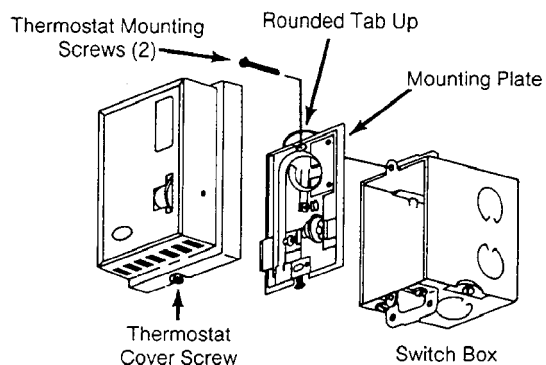

Figure-2 Installation.

CHECKOUT

After installing a thermostat, make an initial check of the switching action. Verify the switch action by using a voltmeter between the proper sides of the switch.

1. Run the setpoint dial to a temperature above ambient. This should cause the thermostat to make a circuit between orange and brown leads.
2. Slowly turning the setpoint dial setting to a lower temperature will first break the circuit between orange and brown leads. The contact blade will be in a neutral position between the two contacts (not making a circuit to either contact). Turning the setpoint further down to a lower temperature will cause the thermostat to make a circuit between orange and red leads.

CALIBRATION

All thermostats are calibrated at the factory and normally will not require any such attention. However, if calibration is necessary for any reason, proceed as follows:

1. Turn off control power.
2. Set temperature dial to the room temperature, as read from an accurate thermometer.
3. Remove cover. Do not breathe on the thermostat or handle excessively as this will affect the accuracy of the final calibration.

4. If contact blade is made to the left (red lead) contact, use a 1/8" blade screwdriver to turn calibration screw counterclockwise (looking at head of screw) until blade floats between contacts.

Note: Each complete turn of the screw changes calibration approximately 15°F. If contact blade is originally made to the right (brown lead) contact, turn calibration screw slowly clockwise until element floats between contacts. Thermostat is now properly calibrated.

5. Replace thermostat cover.
6. Turn on control power.
7. Recheck calibration after 4 hours to be sure heat from handling did not result in erroneous setting.

MAINTENANCE

Be sure that the air convection holes in the thermostat cover do not become clogged or covered. This causes improper temperature sensing.

After long periods of continual use, it may become necessary to clean the contacts of any excess contact build-up. Before proceeding, be sure that either the electrical connections to the thermostat are disengaged or that the power to the circuit is broken. Now clean the contacts using TOOL-13 contact burnishing tool.

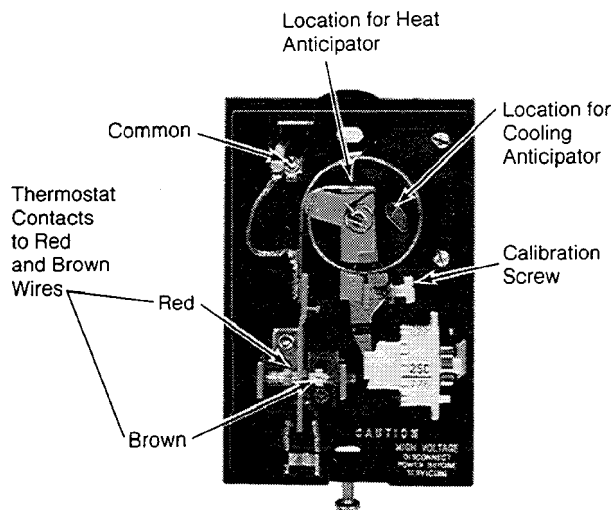

Figure-3 Thermostat Less Cover.

REPAIR

None. Replace entire unit.

Copyright 2008, TAC
All brand names, trademarks and registered
trademarks are the property of their respective
owners. Information contained within this
document is subject to change without notice.

F-21666-3

TAC
1354 Clifford Avenue
P.O. Box 2940
Loves Park, IL 61132-2940
www.tac.com

t.a.c. [®]
by **Schneider Electric**