



Important: Read and save these instructions. This guide to be left with equipment owner.



RH2+

Installation and Operation Manual

Includes installation, operation
maintenance and troubleshooting
information for your RH2+ Electric
Steam humidifier

Thank you for choosing Nortec.

INSTALLATION DATE (MM/DD/YYYY)

MODEL #

SERIAL #

CYLINDER #

Proprietary Notice

This document and the information disclosed herein are proprietary data of **Nortec Humidity Ltd.** Neither this document nor the information contained herein shall be reproduced, used, or disclosed to others without the written authorization of **Nortec Humidity Ltd.**, except to the extent required for installation or maintenance of recipient's equipment.

Liability Notice

Nortec does not accept any liability for installations of humidity equipment installed by unqualified personnel or the use of parts/components/equipment that are not authorized or approved by Nortec.

Copyright Notice

Copyright 2015, **Nortec Humidity Ltd.** All rights reserved.

Contents

1	Introduction	
2	Receiving and Unpacking	
3	RH2 Models	
4	Options and Accessories	
5	Installation	
6	Typical RH2 Installation	
7	Location	
8	Mounting with Keyholes	
9	Plumbing	
10	Steam Distributor	
12	Steam Lines and Condensate Return Instructions	
16	Electrical	
17	External Controls	
22	Options and Accessories	
23	Start Up	
24	Installation Check	
25	On/Off or Modulating Operation	
26	Start Up Procedure	
27	Nortec Digital Controls	
28	RH2 Pre-Start Up Checklist	
31	Operation	
32	LED Status Lights	
32	Selecting a Relative Humidity Setpoint	
33	Humidifier Components	
34	Description of Components	
35	Humidifier Schematic	
36	How the Humidifier Works	
38	Humidifier Configuration	
40	Maintenance and Servicing	
41	Required Maintenance	
45	Extended Shutdown	
46	RH2 Maintenance Checklist	
47	Troubleshooting	
49	General Troubleshooting	
51	RH2 Faults	
53	RH2 Wiring Diagrams	
54	Spare Parts	
58	Warranty	

Introduction



CAUTION: Servicing

- Disconnect main power before any servicing.
- The plumbing and electrical compartments contain high voltage components and wiring. Access should be limited to authorized personnel only.
- During and following operation of the humidifier, the steam and components in contact with the steam such as the blower pack, steam lines, steam distributors, and condensate lines can become hot and can burn if touched.
- Nortec does not accept any liability for installations of humidity equipment installed by unqualified personnel or the use of parts/components/equipment that are not authorized or approved by Nortec.



CAUTION: Electrical

- All electrical work should be done according to local and national electrical code.
- Electrical connection to be performed by a licensed electrician.



CAUTION: Plumbing

- Plumbing to be performed by a licensed plumber.
- Drain water from humidifier can be very hot. Do not drain to public sink.
- All plumbing work should be done according to local plumbing code.



CAUTION: Installation

- Do not mount on hot surfaces.
- Do not mount in area where freezing can occur.
- Do not mount on vibrating surface.
- Do not mount on floor.
- The RH2 produces steam at atmospheric pressure. No devices which could block steam output should be connected to the steam outlet.
- Steam lines must be installed so that no restriction can produce backpressure in the humidifier.
- Regardless of selecting on/off or modulating control method, Nortec humidifiers must have a closed circuit across its on/off security loop control terminal to operate. Nortec highly recommends the use of a high limit humidistat.

RH2 Models

The RH2 is the most advanced residential steam humidifier available and provides steady and reliable humidification for a home using the same proven cylinder technology as Nortec's industrial electrode platform. The RH2 is available in 2 models: Duct, and Space. The duct model is designed for connection to a steam distributor installed in a supply air duct, or for connection to a remote blower pack. The space model is designed for applications where humidity is to be introduced directly into the conditioned environment. The two models can be differentiated by the grille in the humidifiers front cover, see Figure 2: RH2 Models.

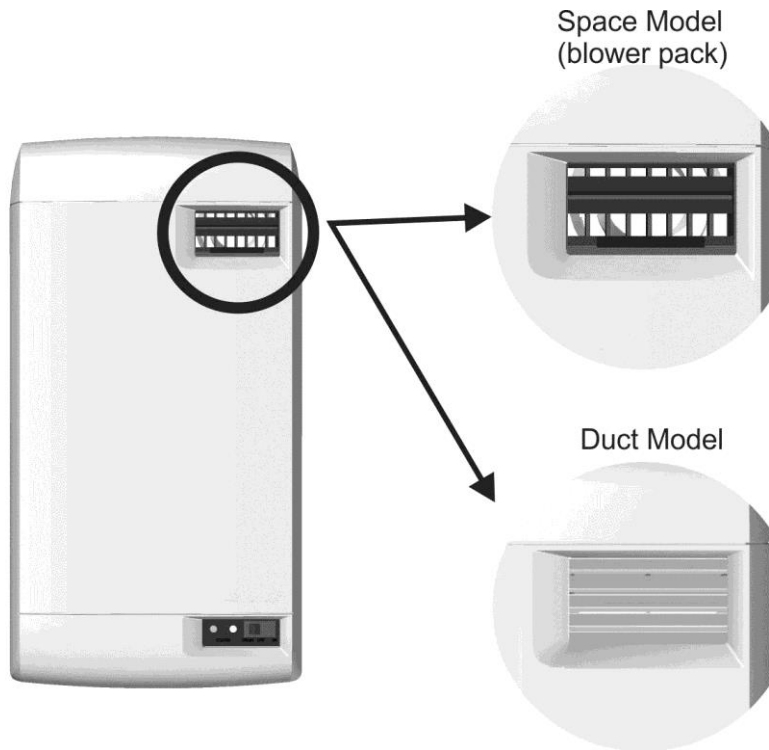

Figure 2: RH2 Models

Table 1: RH2 Specifications

Model - Part No.	Volts	Capacity lb (kg)	KW	Amps	Phase	Max Ext Fuse	Standard Cylinder	Net/Full Weight lb (kg)
RH2 Space - 2560952	110-120	4 (1.8)	1.5	12.7	1	20	202	16 / 22 (7.5 / 10.0)
	208	6.9 (3.1)	2.6					
	220-240	8 (3.6)	3.0					
RH2 Duct - 2560953	110-120	5 (2.3)	1.9	15.9	1	20	202	15 / 21 (7.0 / 9.5)
	208	8.7 (4.0)	3.3					
	220-240	10 (4.6)	3.8					

Options and Accessories

Nortec provides a complete line of options and accessories for every humidification application. The following options and accessories are available and may have been delivered with your RH2 humidifier. Refer to the installation instructions that came with the accessories for proper installation and operation.

Table 2: Options and Accessories

Option / Accessory	Application
Steam Distributors	Introducing steam into ventilation ducts.
Remote Blower Pack	Introducing steam into conditioned environments.
Digital or Modulating Control Humidistats	Controlling the output of the humidifier based on sensed RH.
Digital or Modulating High Limit Humidistats	Preventing over-humidification in a duct by shutting down or throttling down the humidifier when RH approaches saturation.
Air Proving Switches	Ensuring humidification only occurs when air is moving in a duct.

Installation

6	Typical RH2 Installation
7	Location
8	Mounting with Keyholes
9	Plumbing
10	Steam Distributor
12	Steam and Condensate Returns
16	Electrical
17	External Controls
17	Control Wiring
17	Duct Humidification Control Location
18	Space Humidification Control Location
19	On/Off Control Wiring
20	Modulating Control Wiring
21	Fan Enable Wiring
21	RH2 Fan Control
21	Nortec On/Off Humidistat Fan Control
22	Options and Accessories
22	Remote Blower Pack

Typical RH2 Installation

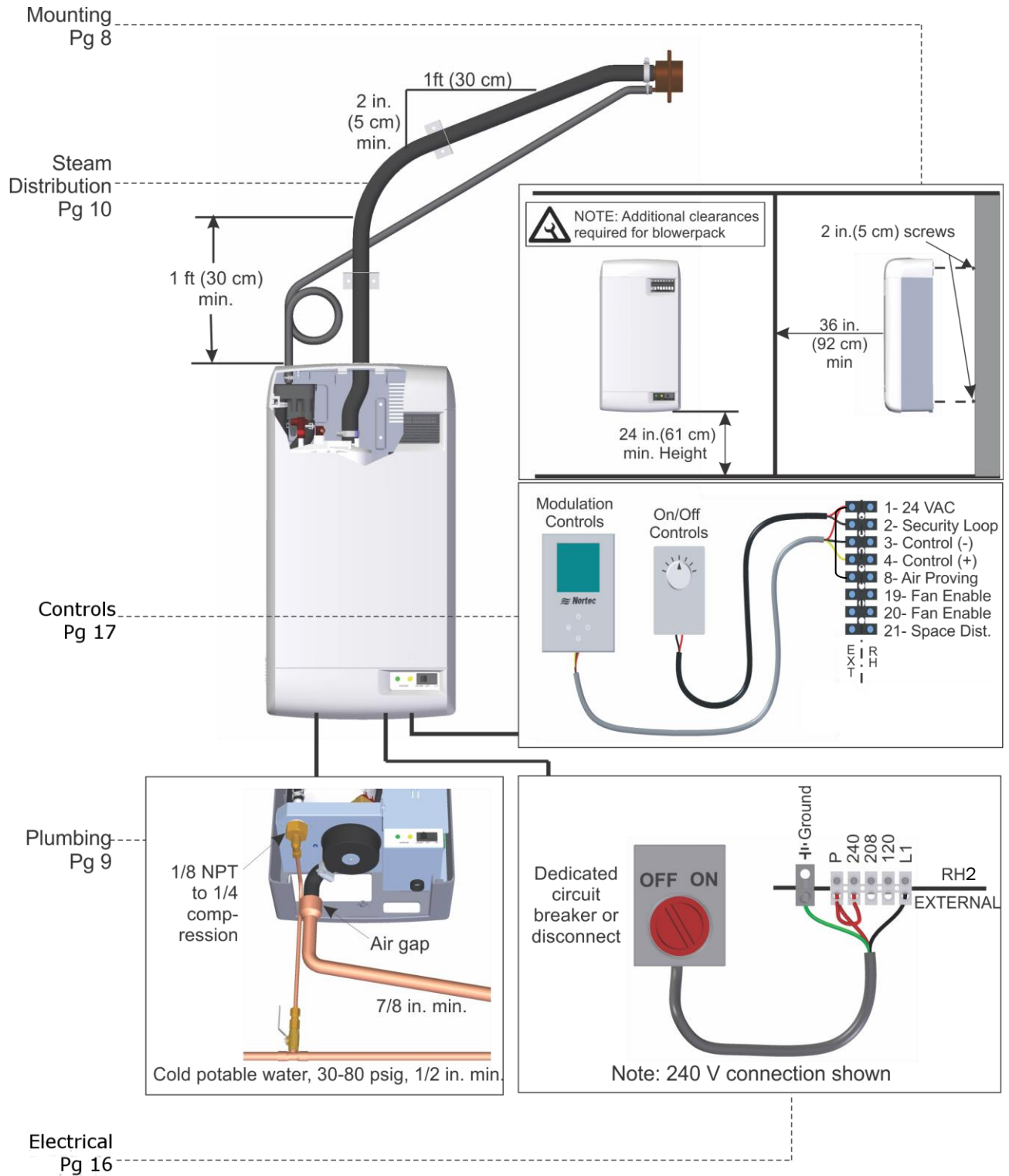

Figure 3: Typical Humidifier Installation

Location

Mount on a suitable wall or vertical surface. Do not sit the unit on the floor. Allow clearances required for plumbing and electrical connections. Clearance dimensions shown are for reference only and are the minimum required for maintenance of the humidifier. Consult local and national codes before final location and installation. Nortec does not accept responsibility for installation code violations.

- Install only in areas with ambient temperature 41-104°F (5 – 40°C) relative humidity 5 - 95%.
- When possible install below the steam distributor. Take care to provide proper steam line routing and proper condensate traps.
- DO NOT locate the humidifier any further then absolutely necessary from the steam distributor location as net output will be reduced as a result of heat loss through the steam line.
- When possible, mount the RH2 humidifier at a height convenient for servicing.



Note: Do not mount on hot surfaces, where freezing can occur, vibrating surface, or floor.

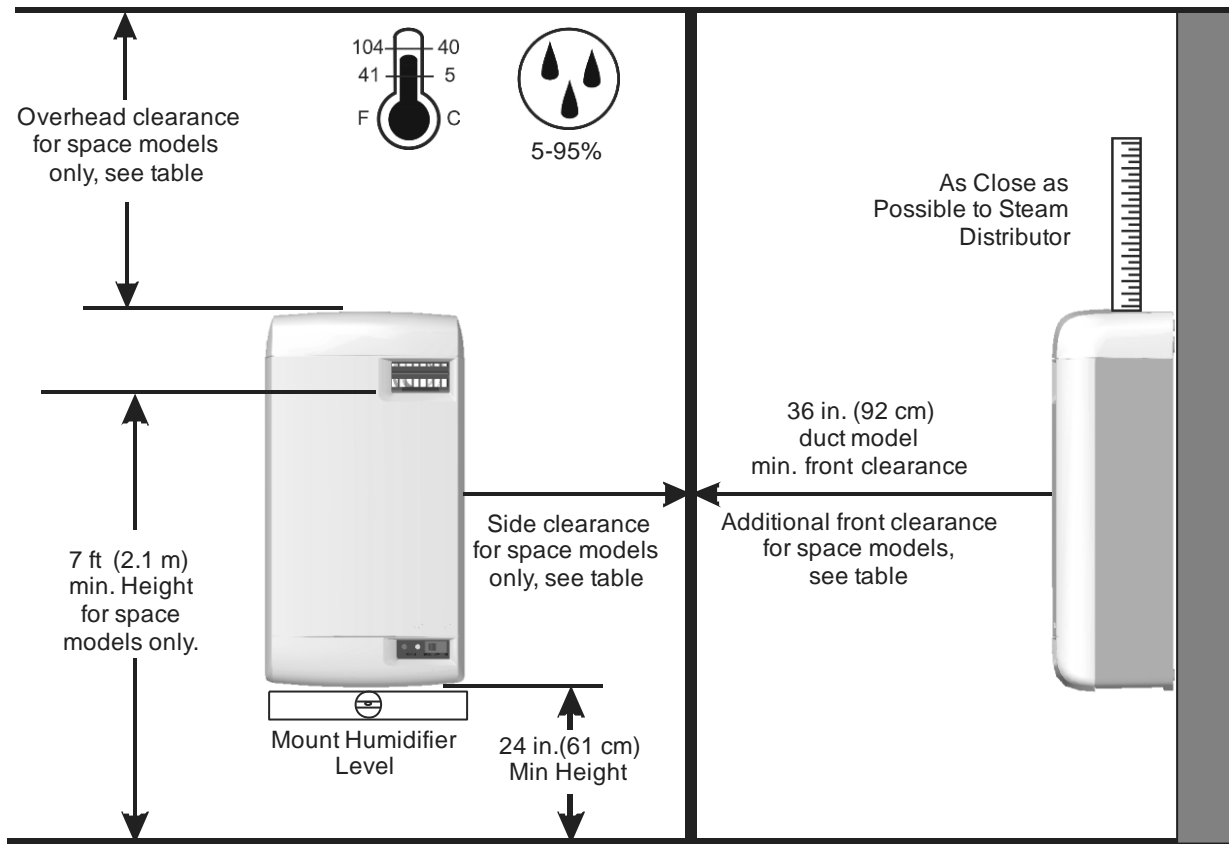

Humidifier Output lb (kg)	Additional Clearance for Space Models Only		
	Side in. (cm)	Overhead in. (cm)	Front in. (cm)
<4 (1.8)	12 (30)	12 (30)	36 (92)
6 (2.7)	16 (40)	18 (46)	42 (107)
8 (3.6)	18 (46)	18 (46)	48 (120)

Figure 4: Mounting Location / Clearance

Mounting with Keyholes

- 1 The RH2 humidifier is wall mounted using a keyhole located on the back of the unit cabinetry.
- 2 Use #8 x 2 in. (5 cm) screws mounted into 2x4 studs or better. 2 screws are needed, one for hanging the unit and one for securing so it will not lift off the keyhole.
- 3 Install the top screw so that 1/4 in. (6 mm) is exposed. Raise the unit and place the screw head through the keyhole.
- 4 Make sure the unit is level and then insert and tighten the second screw through the bottom hole. Tighten the top screw. See Figure 5: Mounting With Keyholes.

Note: Use screws longer than 2" (5 cm) if drywall or other spacer is present.

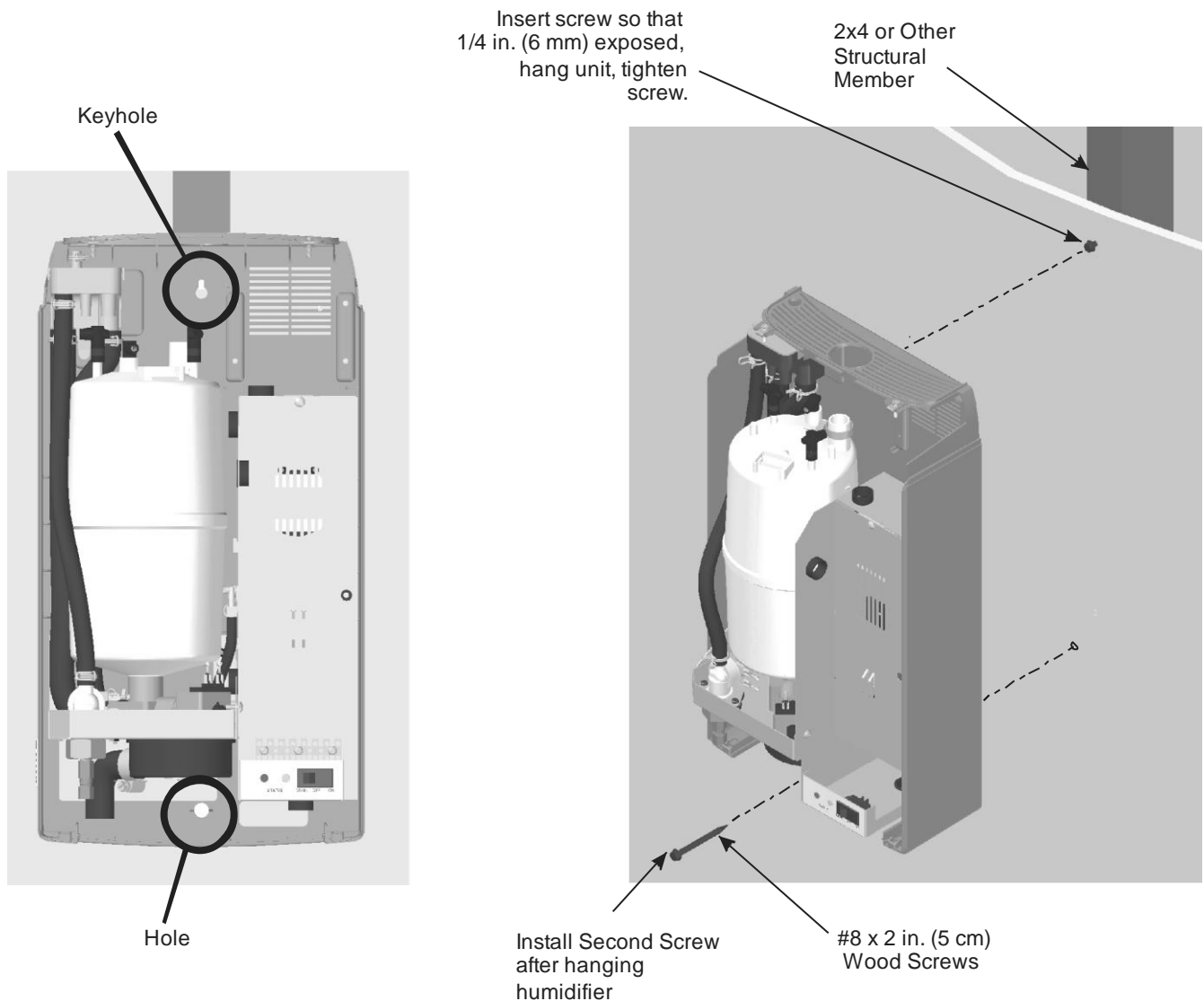

Figure 5: Mounting With Keyholes

Plumbing

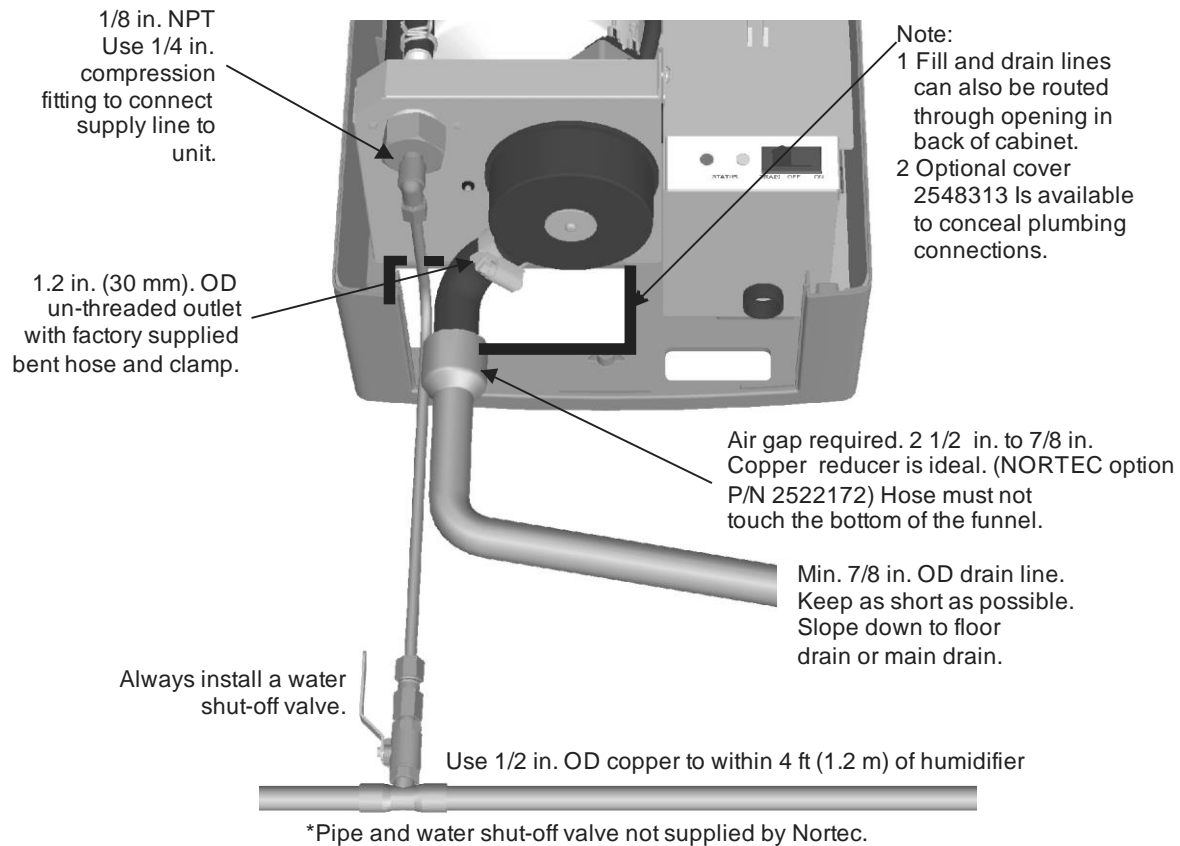

Figure 6: Water Supply and Drain Connection



- All water supply and drain line connections should be installed in accordance with local plumbing codes.
- Drain water is automatically cooled to 140°F (60°C). Drain material must be rated for this temperature.

- Supply water should be at 30 to 80 PSIG and be between 150-1200 Microsiemens (330-670 µS optimal range). Consult factory for water conditions outside of this range. Do not use reverse osmosis or de-ionized water. Supply water should be cold (34-68°F/1-20°C).
- Install water shut off valve before humidifier to facilitate servicing.
- The drain line should not end in a sink used frequently by personnel, or where plumbing codes prohibit it. Route to a floor drain or equivalent for safety reasons.
- Ensure drain line is adequately sized to provide free and easy draining and that an air gap is installed as shown. A restricted drain can cause cylinder water to over concentrate and result in poor operation.
- If a drain is not located near the humidifier use a condensate pump rated for hot drain water such as Nortec's Part Number 1429527.



For humidifiers installed in some cities including the City of Los Angeles:

A city-approved spring-loaded double ball CHECK VALVE must be installed by contractor on the potable water inlet to the humidifier. Recommended valve manufacturer: Watts Regulator, phone number 508-688-1811, Size depending on supply line 1/4", 3/8", or 1/2" NPT inlet and outlet, Model #7.

Steam Distributor

- Steam generated by the RH2 Space is blown directly into the space by the integrated blower pack. The RH2 Duct requires a steam distributor, installed in the ventilation duct. The RH2 Duct can distribute steam into a ventilation duct using the following distributor options in Table 3.

Table 3: RH2 Duct Steam Distributor Options

Nortec Part Number	Option Description	Notes
1581820	Nozzle Distributor Kit	Includes a steam distribution nozzle, steam hose, condensate hose, and installation hardware. See Figure 7.
2553708	RSD 10 Distributor Kit	Includes a steam distributor, steam hose, condensate hose, and installation hardware. See Figure 8.
Select to duct dimensions	ASD Duct Distributor	Used when duct width exceeds 12". Refer to Distributor manual or HELP software for selection.
Select to duct dimensions	Mini SAM-e	Used when short absorption is necessary. Refer to SAM-e manual or HELP software for selection.
2564776	RMBP for RH2 Duct	Remote Mounted Blower Pack, used with the RH2 Duct, adds steam directly into the space. The blower pack is installed remote to the humidifier.

- Whichever method is used, the steam distributor should be installed as close as possible to the humidifier. Short steam distribution lines minimize condensate losses and the possibility of generating backpressure in the steam distribution line.

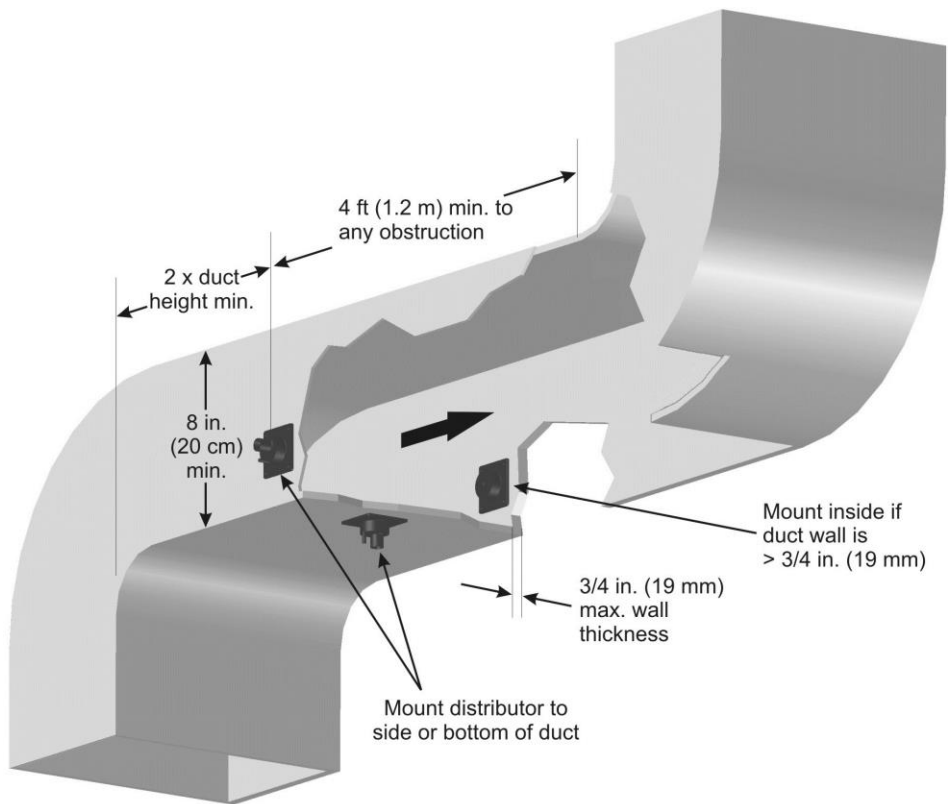

Figure 7: RH2 Duct Nozzle Distributor Installation

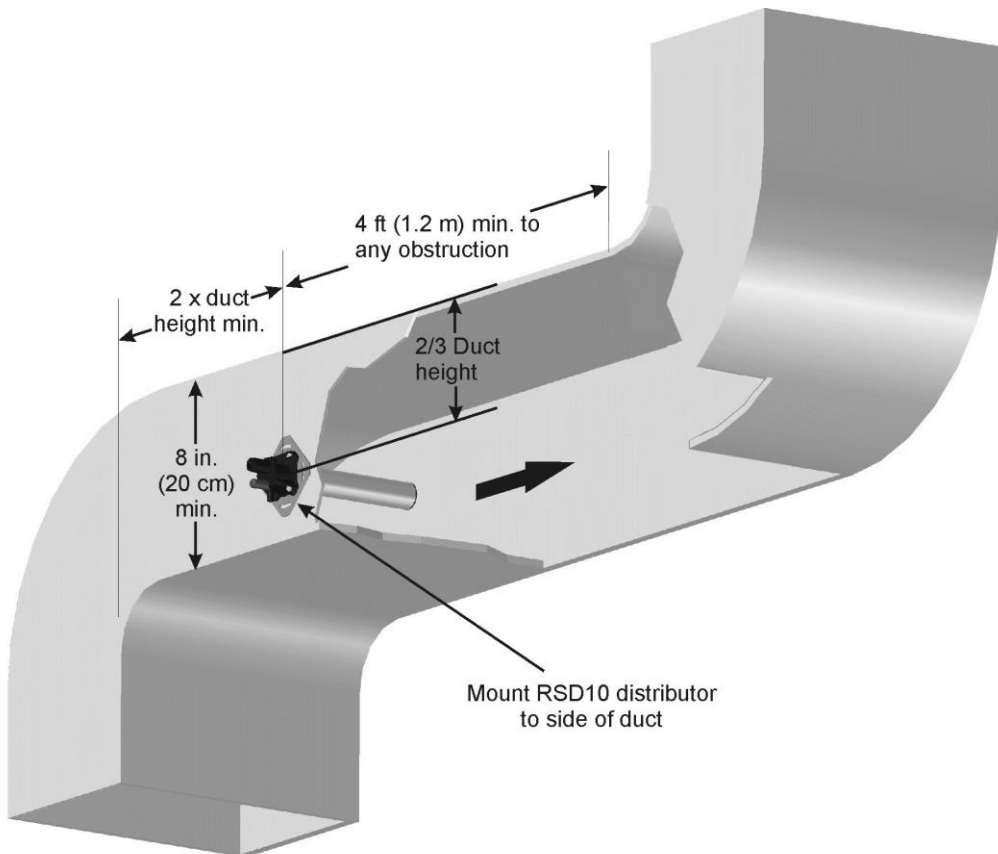

Figure 8: RH2 Duct RSD10 Distributor Installation

Steam Lines and Condensate Return Instructions

The following instructions must be followed for installation of steam lines for the RH2 Duct. Failure to use recommended material and exceeding maximum recommended length in Table 4, or failure to follow any other steam line installation instructions will result in improper operation and could void the warranty.

Table 4: Recommended Steam Line Material for RH2 Duct

Voltage	Steam Output		Material*			Maximum Steam Line Length		Possible Losses	
	lbs/hr	(kg/hr)	Nortec Steam Hose	MED-L Copper Tube	Stainless Steel Tube	ft	(m)	lbs/hr	(kg/hr)
110-120V	5	(2.3)	Part Number 1328810 (7/8")	3/4"	0.875 X 0.049W	7	(2)	0.5	(0.2)
208V	8.7	(3.3)				10	(3)	1	(0.5)
220-240V	10	(4.6)				12	(3.5)	1.5	(0.7)
Oversized Steam Line (used for longer steam runs)**									
110-120V	Not Recommended		Not Recommended	1"	1.125 X 0.049W	Not Recommended			
208V	8.7	(3.3)				12	(3.5)	2	(0.9)
220-240V	10	(4.6)				24	(7)	3	(1.4)

Note: * The use of steam line other than copper, stainless steel tube or Nortec supplied steam line will void the warranty and may adversely affect the operation of the humidifier.

** These diameters require a reducer at humidifier and steam distributor connection. Use Nortec part number 1115444 at humidifier to prevent backpressure caused by condensation collecting at the reduction.

To return condensate for RH2+, insert copper tube (supplied with equipment) half way into the condensate opening of the fill cup along with the spring clamp (supplied with equipment).

Insert the condensate hose into the condensate return hole at the top of the RH unit, and over the copper tube. Fasten in place with the spring clamp.

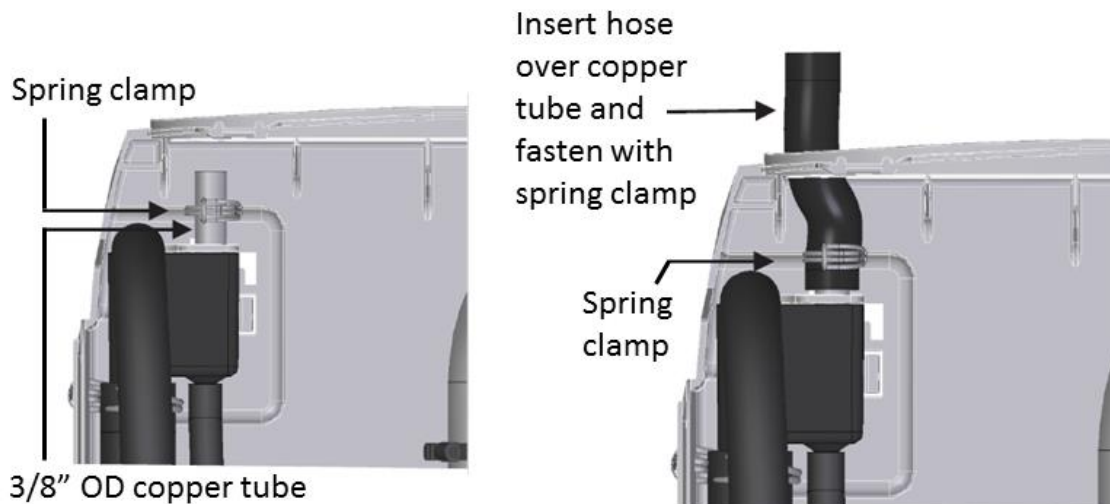

Figure 9: Condensate Return



MAIN RULES FOR ATMOSPHERIC STEAM LINES

- Steam lines must not have any restrictions which could result in back pressure.
- Follow recommended materials, size and length, see tables.
- Slope the steam lines.
- Insulate with 1.0 in. (2.5 cm) pipe insulation
- Trap condensate (Use full size 'T' for Traps)
- Do not over tighten hose clamp at cylinder steam outlet. The maximum torque is 12 in-lbs.
- Support steam line so weight is not on cylinder.
- Condensate traps must be a minimum of 6 in. (15 cm) in height or duct static pressure + 2 in. (5 cm), whichever is greater.
- Trapping by P-trap or pigtail. Support line as necessary to ensure it remains free of kinks.

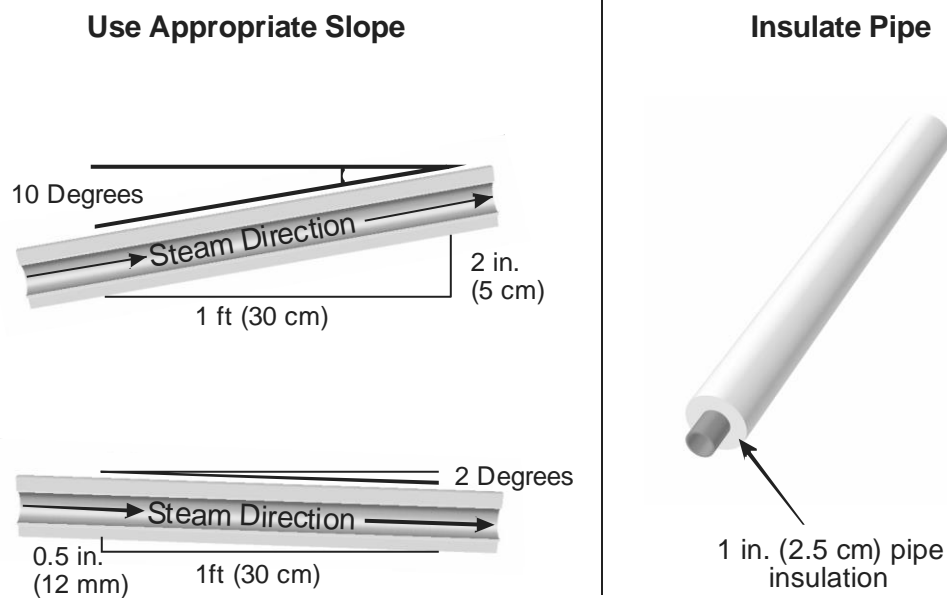

Figure 10: Main Steam Line Requirements

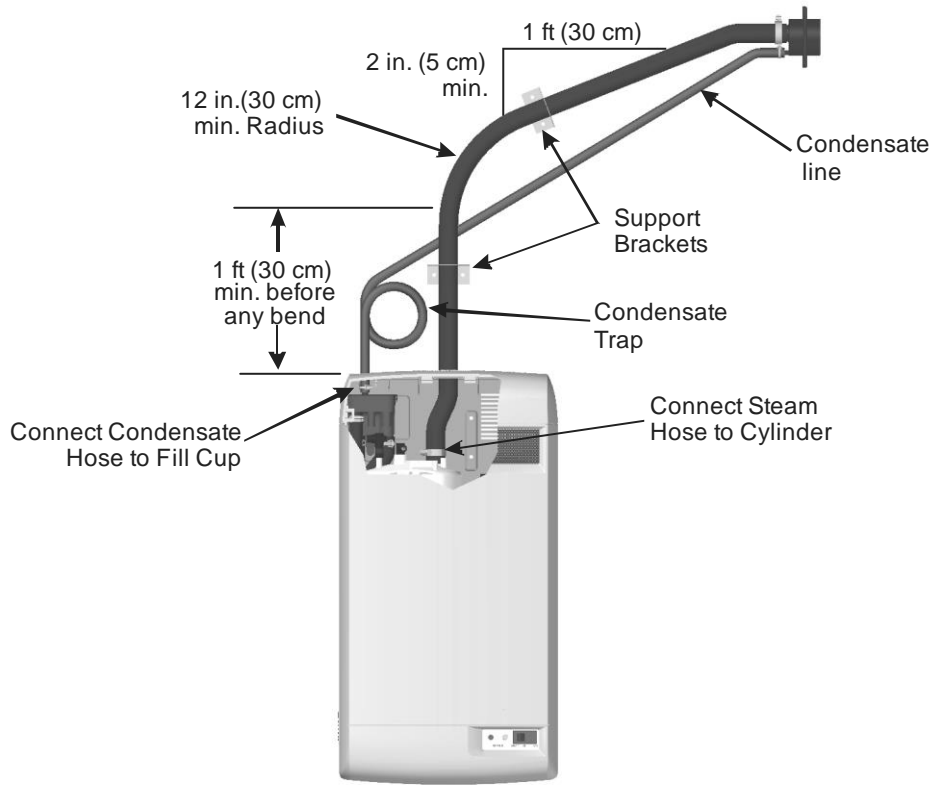

Figure 11: Steam Distributor Above Humidifier (Hose)

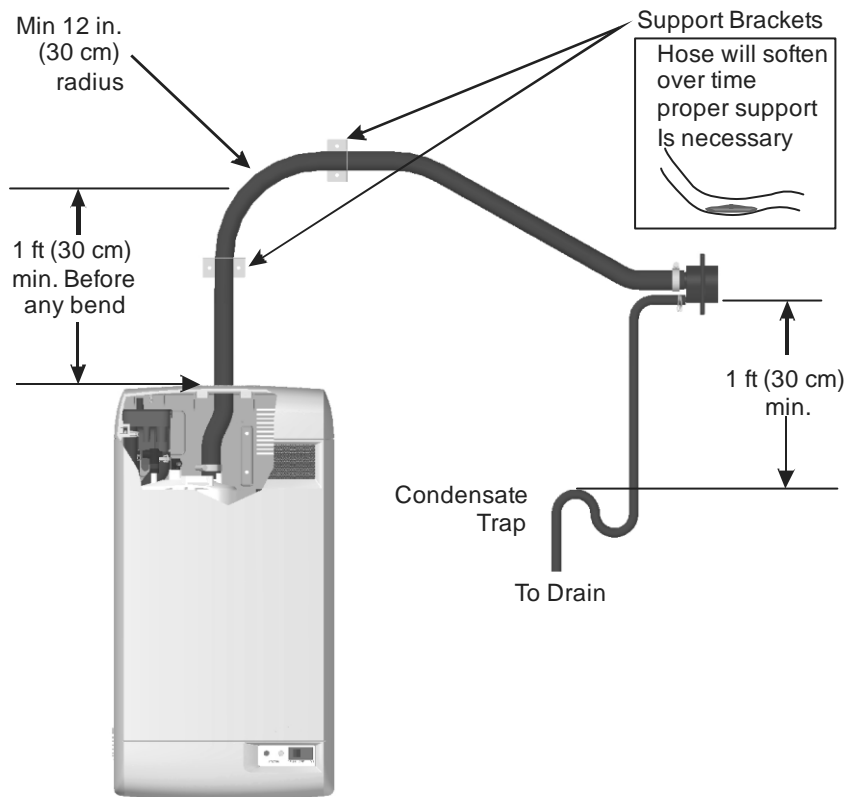

Figure 12: Steam Distributor Below Humidifier (Hose)

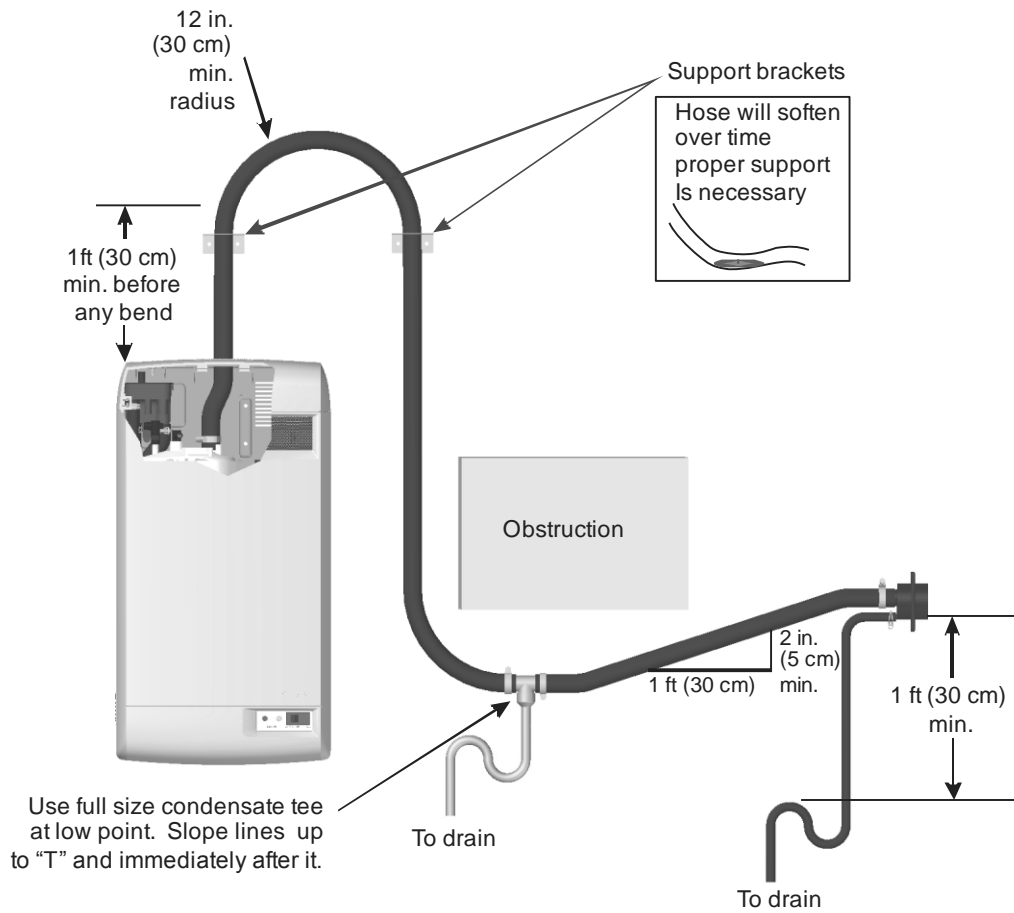

Figure 13: Steam Distributor Below Humidifier With Obstruction (Hose)

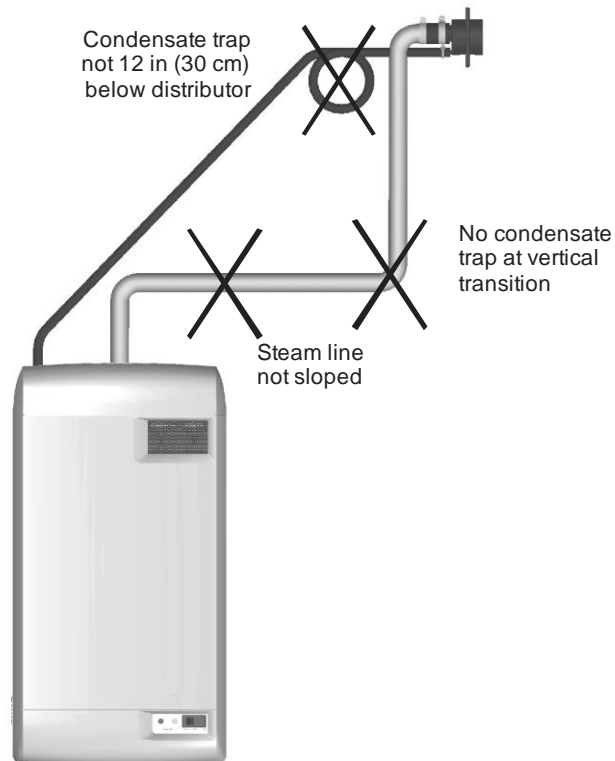
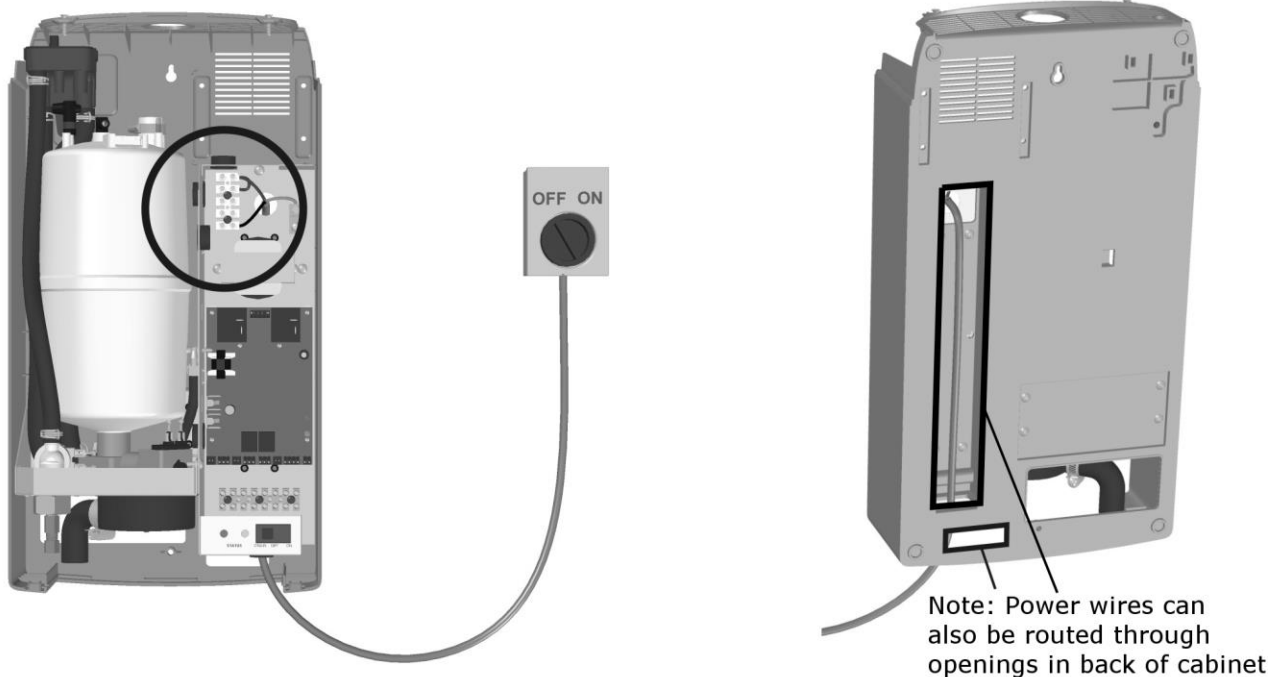

Figure 14: Common Steam Line Errors

Electrical

Caution: Wiring to be performed by a licensed Electrician.



Note:

- 1 Install jumper between P and terminal that corresponds to supply voltage.
- 2 Dedicated external fused disconnect must be installed. Fusing must not exceed max circuit protection as indicated on the specification label.
- 3 Ensure that adequate power is available to carry full humidifier amp draw as indicated on the specification label.
- 4 Do not use neutral wire as a ground; connect dedicated ground to ground termination.
- 5 All Wiring to be in accordance with national and local electrical codes.

240 VAC (1 phase)

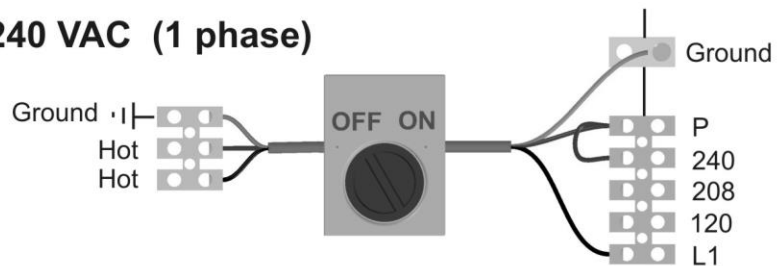

208 VAC (1 phase)

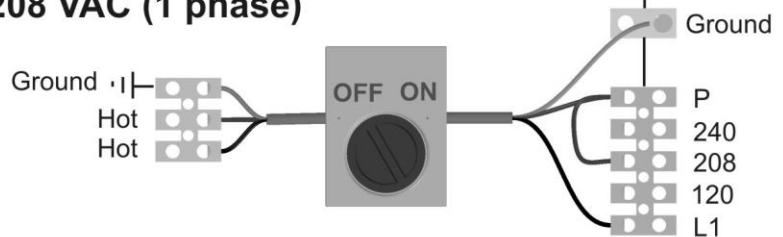

120 VAC (1 phase)

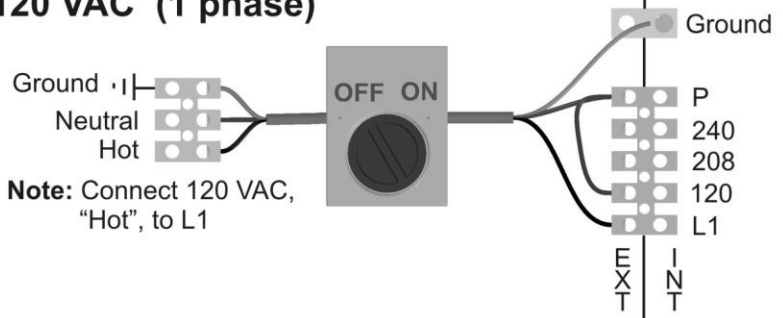

Figure 15: Primary Power Connection

External Controls

Control Wiring

Controls are available from Nortec as accessories. If controls were not ordered with humidifier, they must be purchased or supplied by others. The following information is relevant to all controls, factory supplied or otherwise. For wiring use minimum 18 AWG and keep as short as possible.

The RH2 humidifier can be operated with either On/Off controls only or with On/Off controls and one modulating input. The modulating input can be from a duct high limit or humidity control humidistat. See Humidifier Configuration on page 38 to configure the RH2 for modulation.



Caution: Failure to wire the humidifier in accordance with the wiring instructions could cause permanent damage. Such errors will void the warranty.

Duct Humidification Control Location

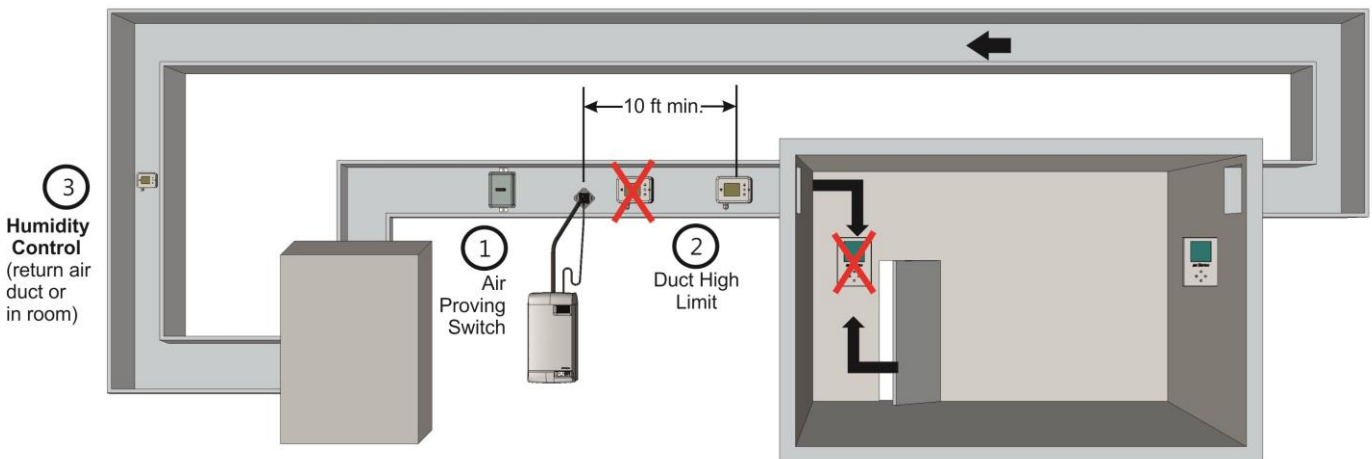

Figure 16: Control Location (Duct Humidification)

Duct Humidification Control Location

- 1** Air Proving Switch
 - Locate upstream so that it can sense air flow or lack of it.
- 2** Duct High Limit – Can be modulating or On/Off humidistat.
 - Locate at least 10 feet downstream from steam distributor or far enough that under normal conditions steam is fully absorbed.
- 3** Humidity Control - Can be Modulating or On/Off humidistat
 - Can be located either in return air duct (preferred) or in room being humidified.
 - Avoid placing near discharge diffuser of humidified air.
 - Mount in area representative of room humidity (draft, doorways, sunlight, or overhang such as a shelf can affect reading).
- 4** Outdoor Temperature Sensor (not shown)
 - Mount outside in area representing air temperature.

Space Humidification Control Location

These instructions apply to the RH2 Space and the RH2 Duct with Remote Blower Pack.

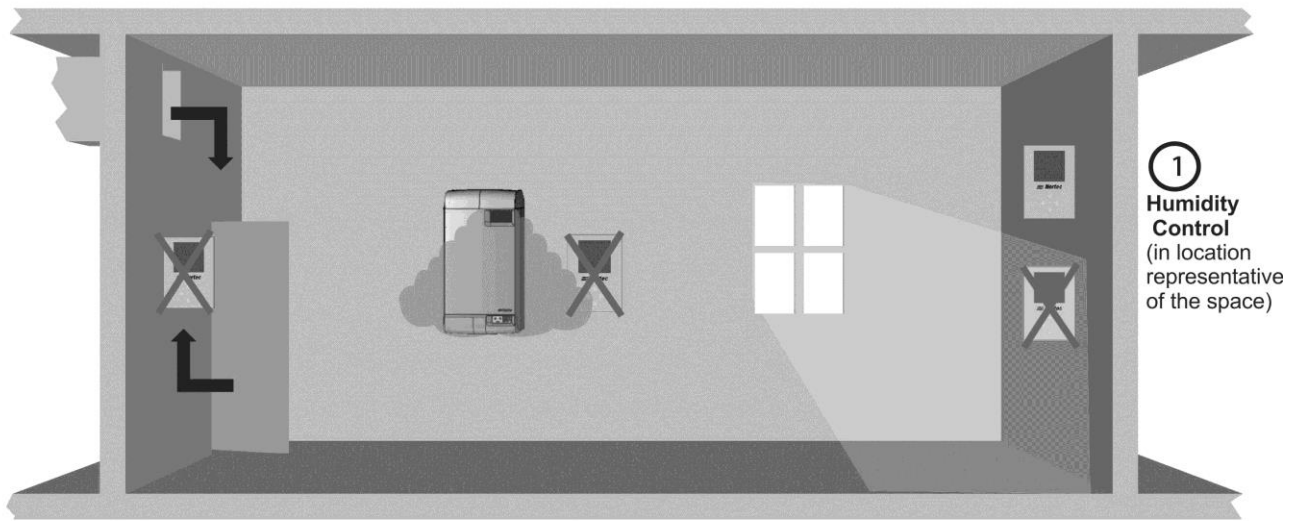

Figure 17: Control Location (In-Space Humidification)

Space Humidification

- 1** Humidity Control – Can be Modulating or On/Off humidistat
 - Locate in room being humidified but not in discharge zone of blower pack.
 - Mount in area representative of room humidity (draft, doorways, sunlight, or overhang such as a shelf can affect reading).
- 2** High Limit Humidistat (not shown)
 - Install an On/Off High Limit Humidistat in an area representative of room humidity.
- 3** Outdoor Temperature Sensor (not shown)
 - Mount outside in area representing air temperature.

Note: Regardless of selecting on/off or modulating control method, Nortec humidifiers must have a closed circuit across its on/off security loop control terminal to operate. Nortec highly recommends the use of a high limit humidistat and an air proving switch in series for this function.



On/Off Control Wiring

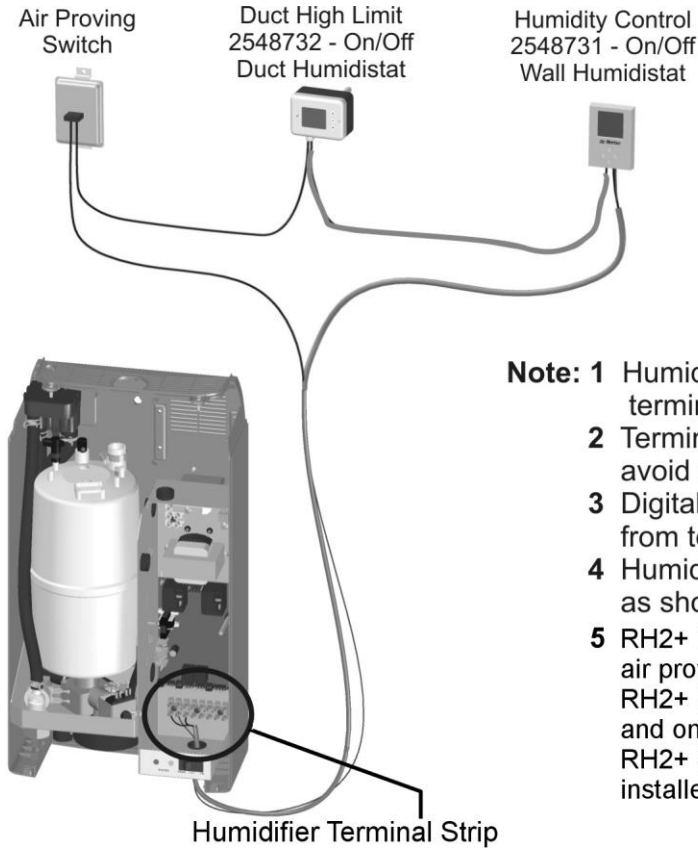

- Note:**
- 1 Humidifier will run when circuit between terminal 1 and 2 on humidifier is closed.
 - 2 Terminal 1 is 24VAC Hot, turn unit off to avoid shorting while wiring.
 - 3 Digital Humidistats require 24 VAC power from terminals 1 and 3 of humidifier.
 - 4 Humidity Control can be wall mounted as shown or return air duct mounted.
 - 5 RH2+ Duct no fan enable = Jumper 1-8 and air proving in series with on/off control 1-2.
RH2+ Duct with fan enable = Air proving 1-8 and on/off controls in series 1-2.
RH2+ Space = Jumper 1-8 (factory installed) and on/off controls in series 1-2.

Figure 18: On/Off Controls

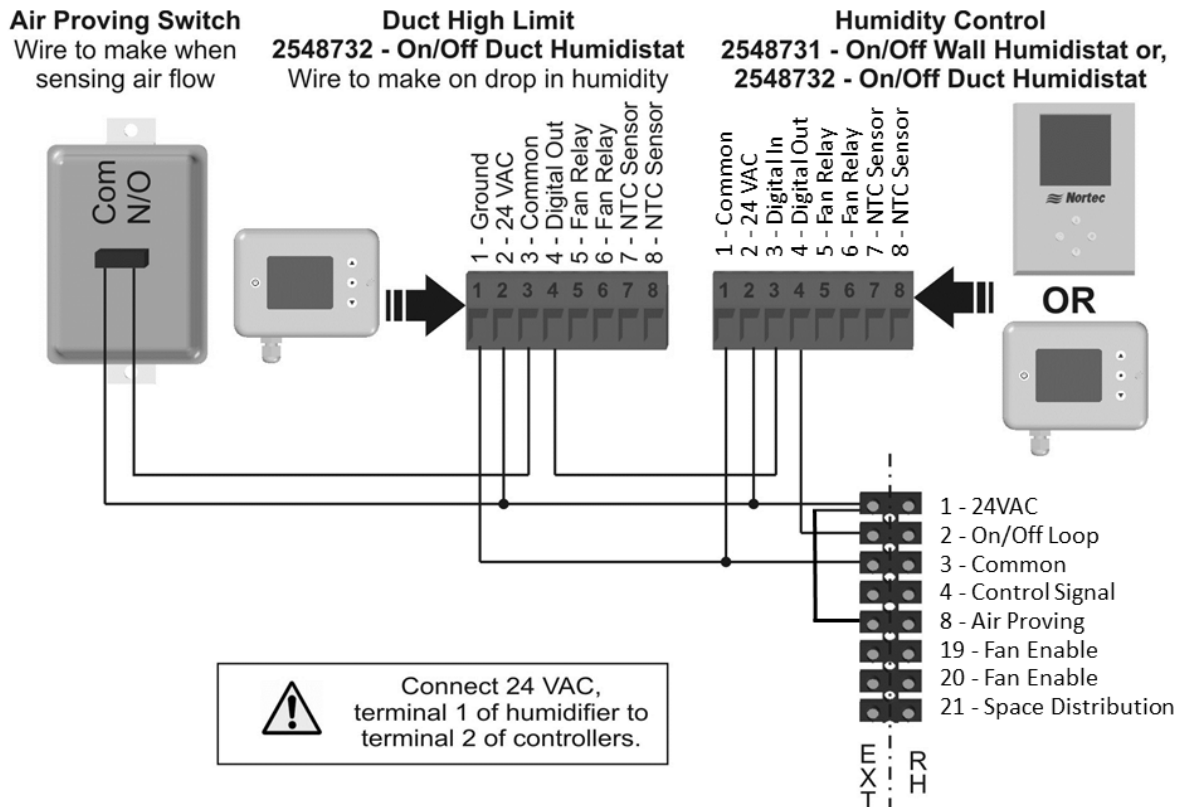

Figure 19: Digital On/Off Humidistat

Modulating Control Wiring

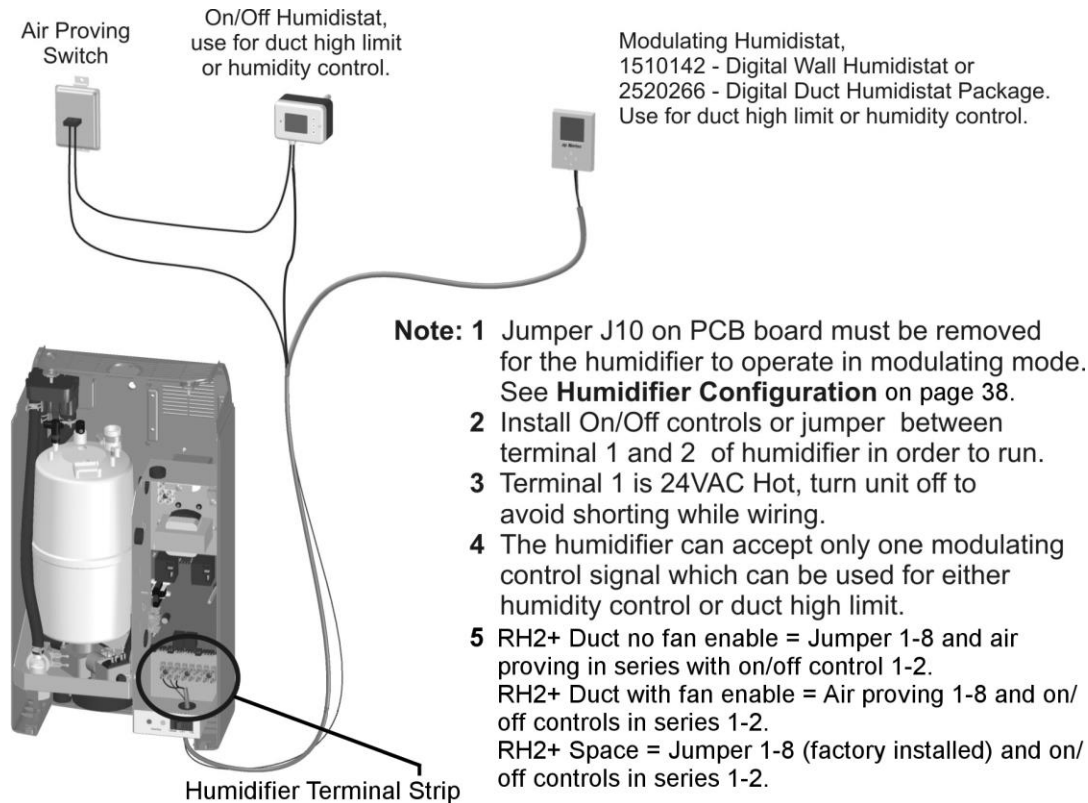

Figure 20: Modulating Controls

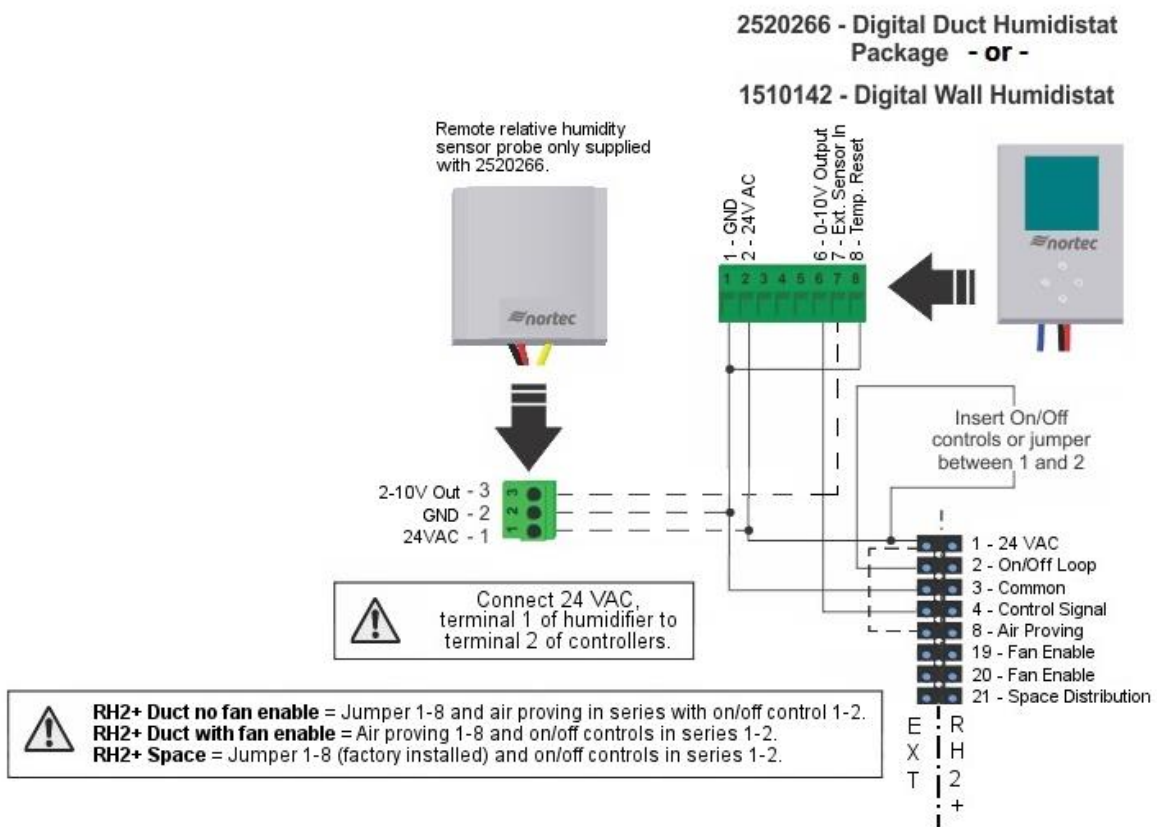

Figure 21: Modulating Control Wiring

Fan Enable Wiring

When distributing steam into a duct, there can be a call for humidity when there is no air flow. Either the RH2 or the Nortec On/Off digital humidistat can be used to enable a fan on a call for humidity. Wiring below is for a typical furnace installation. Consult the air handler's installation manual for exact wiring instructions on how to enable the fan.

RH2 Fan Control

The RH2 can be used to turn on a furnace fan where there is a demand for humidity without a call for heat.

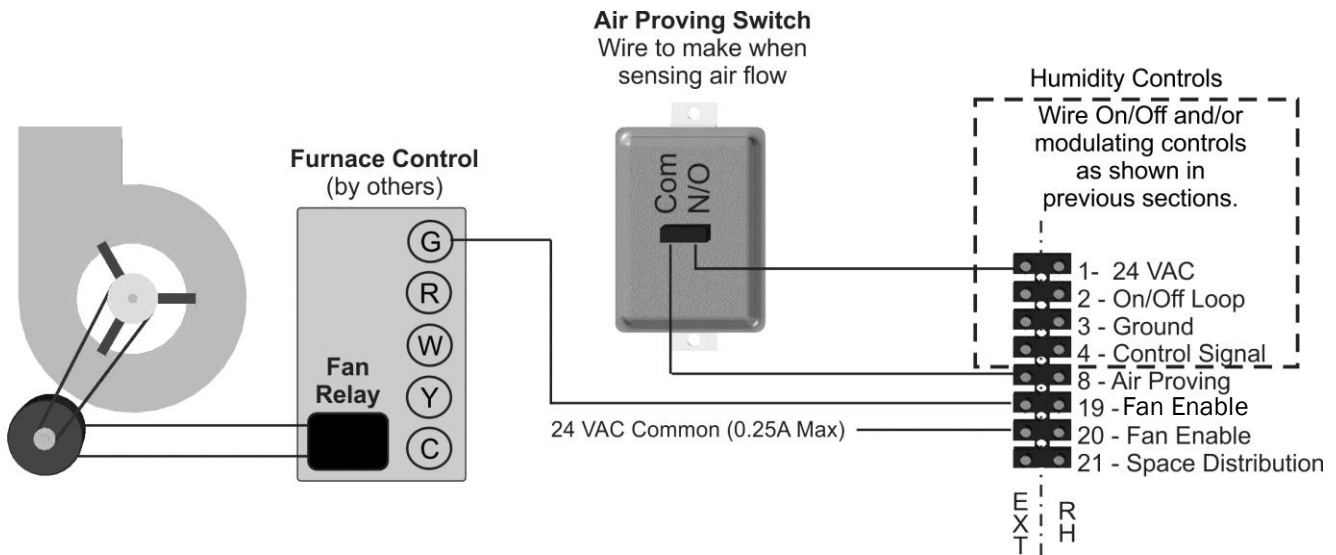

Figure 22: RH2 Fan Enable Wiring

*Humidifier will not start producing steam until fan security loop is closed.

Nortec On/Off Humidistat Fan Control

Nortec digital On/Off humidistats include a second dry set of points to enable a fan where there is a call for humidity without a call for heat.

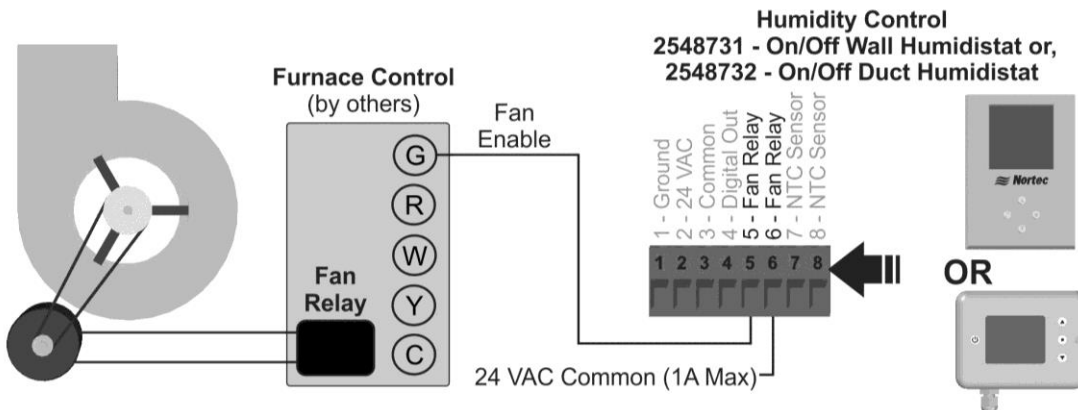

Figure 23: Nortec Digital On/Off Humidistat Fan Enable

Options and Accessories

Remote Blower Pack

A remote blower pack is available for the RH2 Duct for applications where steam for humidification must be introduced directly into the conditioned environment but the humidifier must be installed in a different location.

- For instructions on installing the remote blower pack, refer to the installation instructions supplied with it.
- The steam line instructions in this manual are also applicable to remote mounted blower packs except the slope must be larger because the blower pack does not have a separate condensate line and the maximum allowable steam line length is 4 ft (1.2 m)

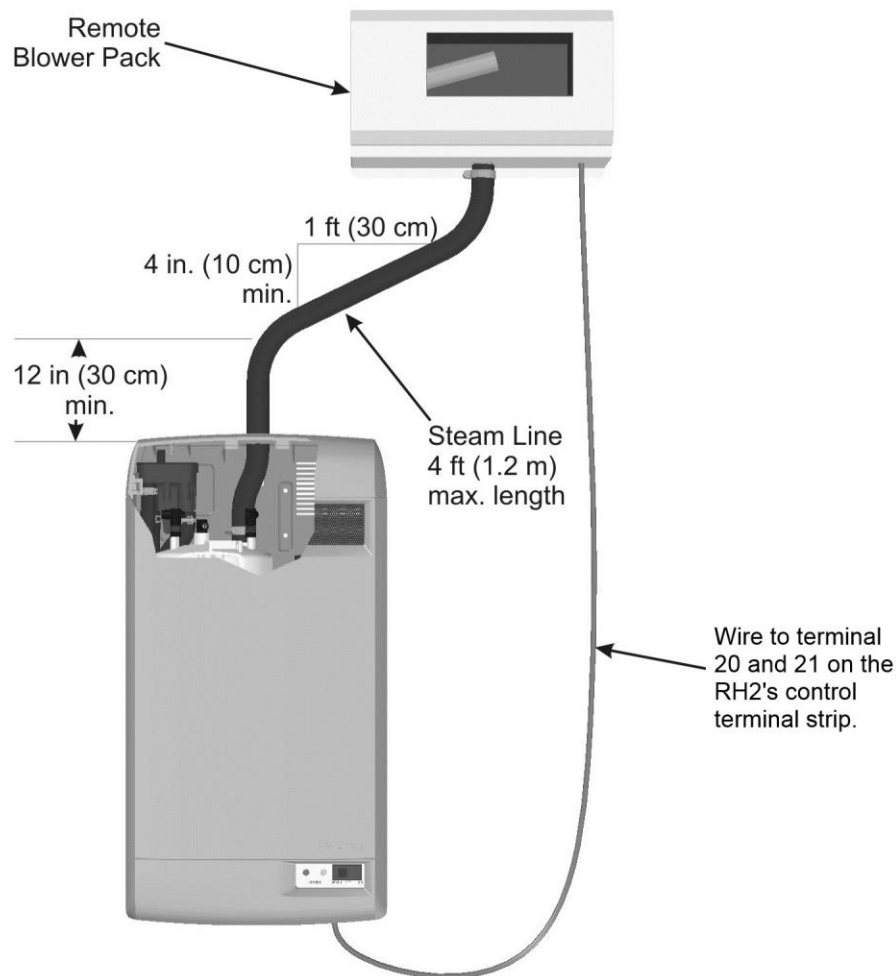

Figure 24: Remote Mounted Blower Pack

Note:

- The blower pack requires additional clearance see the instructions that came with it.
- The steam line slope for the blower pack is 4 in. / 1 ft (10 cm / 30 cm).



Start Up

- 24 Installation Check**
- 25 On/Off or Modulating Operation**
- 26 Start Up Procedure**
- 27 Nortec Digital Controls**
 - 27 Modulating Control
 - 27 On/Off Control
- 28 RH2 Pre-Start Up Checklist**

Installation Check

Before turning on power to the RH2 inspect the installation to ensure that it was carried out correctly. Refer to RH2 Pre-Start Up Checklist on page 28, and to the Installation chapter.

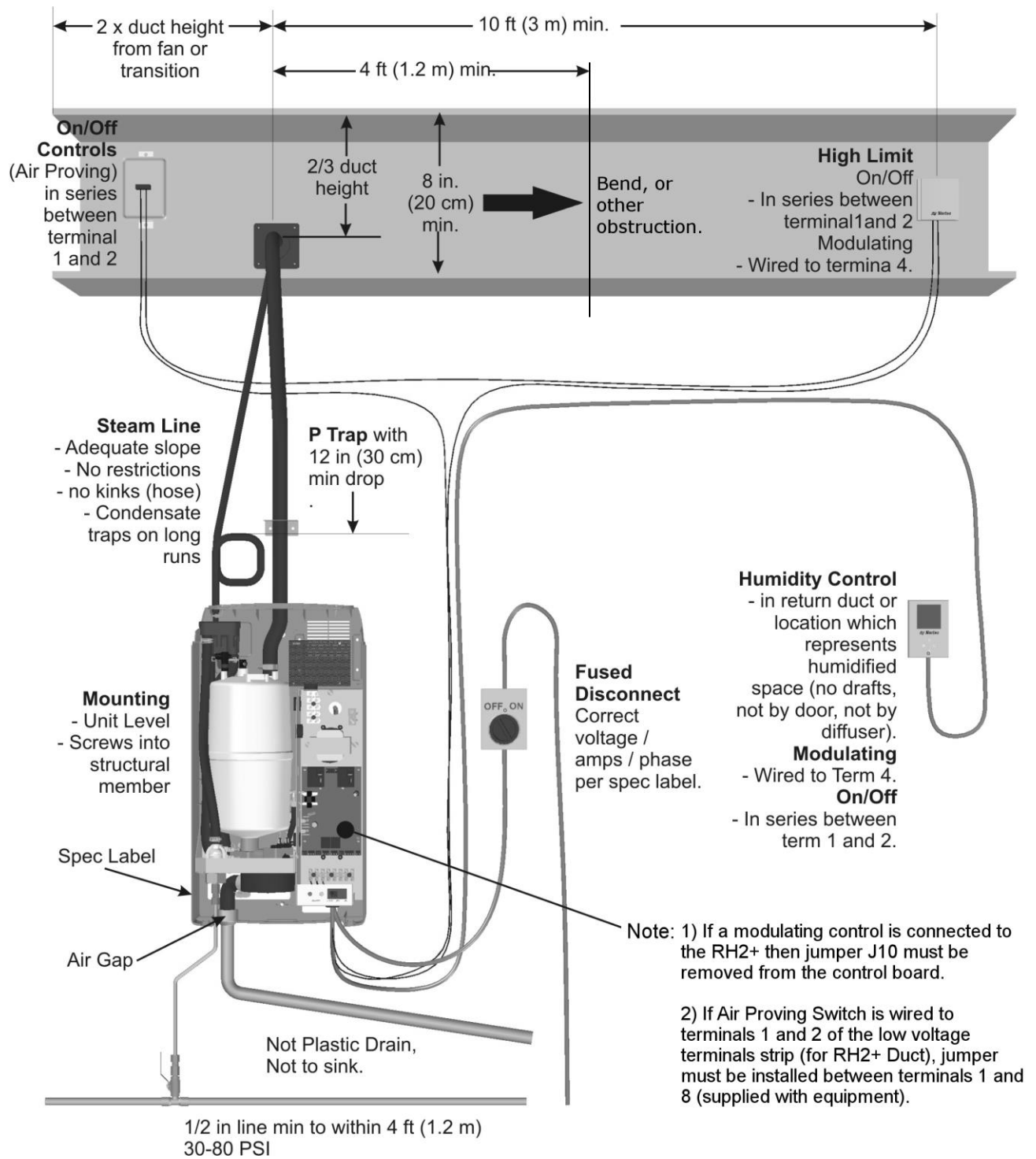

Figure 25: Installation Check



Caution: Do not leave the On/Off/Drain switch in the drain position for extended periods of time. The drain valve solenoid may heat up and result in damage to the valve and its wiring.

On/Off or Modulating Operation

From the factory the RH2 is configured to operate as an On/Off humidifier. It will run when 24 VAC from terminal 1 is fed back into terminal 2 through an On/Off humidistat and other security devices in series. See On/Off or Modulating Control (J10) on page 39 for instructions on configuring the RH2 to operate as a modulating humidifier.

Start Up Procedure

- 1 Examine the humidifier and installation for damage and/or improper installation.
- 2 Ensure the cylinder is properly seated in the drain valve and that the electrode plugs are pushed all the way down on the cylinder pins.
- 3 Ensure that the front cover is in place and secured with its retaining screws.
- 4 Open the supply water shut off valve.
- 5 Turn on the main power using the installed disconnect.

Warning: Damaged Units or improperly installed units must not be operated. Damaged or improperly installed units may present a danger to persons and property.



- 6 Turn the On/Off switch on the front of the humidifier to On.

The humidifier will perform a self-diagnostic sequence during which the LED's and internal components will be momentarily activated. See Figure 27 on page 32 for an explanation of LED colors and sequences.

If an error is detected during the self-diagnostic sequence the humidifier will not start. The yellow status LED will flash in sequence to indicate the detected fault. See section RH2 Faults on page 51 for information on diagnosing and correcting faults.

After the system test the humidifier is in normal operation mode.

- 7 Check and adjust the control setpoint on the control and high limit humidistat.
- 8 When the external humidistat generates a demand for humidity and the security loop is closed the green humidifying LED on the front of the humidifier will light up, the power relay on the control board will engage, the fill valve will activate (after a delay) and the cylinder will slowly fill with water.

Note: While the cylinder is filling with water there should be no water flowing down the drain. If water is flowing down the drain it can indicate excessive backpressure or a leaking drain valve. See chapter on Troubleshooting.



- 9 If the fan enable relay is used, the green LED will continue to flash until the air proving closes. Once the air closes, the flashing green LED will become solid and the humidifier will start steam production as described in step 8.
- 10 It can take 5 – 10 minutes for the water to be heated up by the submerged electrodes and for steam to be produced.

Note: If operated on low conductivity water it may take several hours for the RH2 to reach full output capacity. This is normal. During this time the humidifier will not perform any drains and the conductivity of the water in the cylinder will increase.



Nortec Digital Controls

Nortec provides optional On/Off and Modulating digital controls. Figure 26 show the function and meaning of the Digital Control's display and buttons. All controls are available either wall mounted or with a remote sensor for duct mounting.

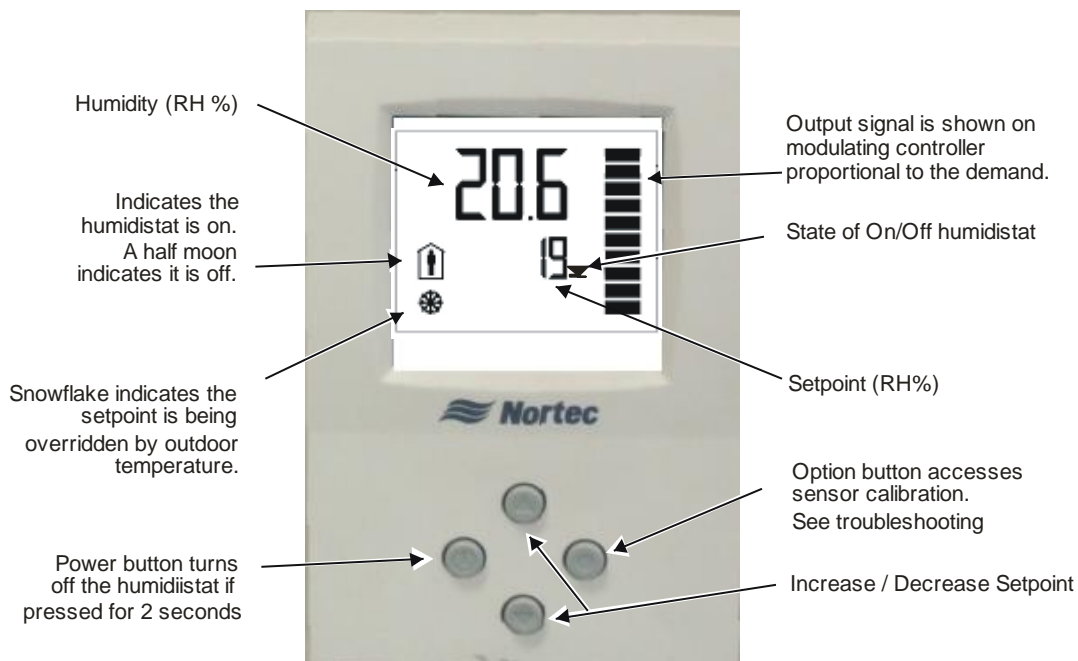

Figure 26: Modulating and On/Off Digital Control Operation

Modulating Control

The modulating controls use a PI control algorithm to transmit a 0-10V control signal to the humidifier. Adjust the setpoint to the desired setting by using the up/down arrow buttons on the controller.

On/Off Control

The On/Off controls use a PI control algorithm to open and close a relay that opens and closes the humidifier's On/Off loop. Adjust the setpoint to the desired setting by using the up/down arrow buttons on the controller.

Note: It is possible to field calibrate Nortec digital controls if the displayed humidity is found to be different than a known trusted source. See chapter on Troubleshooting.



RH2 Pre-Start Up Checklist

Unit Serial #: _____ No. of humidifiers: _____ Tag: _____

Unit type: _____ Voltage: _____V/_____ph

Cylinder type: _____ Customer/Job: _____ Address: _____

WATER QUALITY:

Well water City water Softened water

HUMIDIFIER MOUNTING:

- Level _____
- Front Clearance 36 in.

STEAM LINE(S):

- Material
- Slope up (min 2 in/ft)
- Low point condensate traps
- Minimum 1 inch insulation
- Diameter / Size _____
- Slope down (min 0.500 in/ft)
- No hose kinks / Restrictions

CONDENSATE LINE(S):

- P Trap min 6 in or duct press + 2in
- P Trap min 12 in drop

WATER LINE:

- 1/2 in to within 4ft of unit
- Cold water source (34-68°F/1-20°C)
- Water pressure: 30-80 psig

DRAIN LINE:

- Air gap within 3 ft of the unit
- Diameter / Size _____

CYLINDER:

- Seated in drain valve yes no
- Torque for gear clamp of cylinder steam exit to steam line (max 12 in • lbs): _____

WIRING:

- Wiring connections and connectors secured yes no

CONTROLS:

- On / Off / Security loop devices working correctly yes no
- Jumper J10 set to
Modulating (removed)
Or
On/Off (installed)
- Control Location _____
- High Limit Location _____

POWER:

- Voltage, amp, fuse per Spec Label: yes no
- Disconnect switch located close to humidifier yes no
- Panel Number _____

Inspected by: _____ Date of inspection: ____/____/____

Company: _____

RH2 Start Up Checklist

Unit Serial #: _____ No. of humidifiers: _____ Tag: _____
Unit type: _____ Voltage: _____V/_____ph
Cylinder Type: _____ Customer/Job: _____ Address: _____

PRELIMINARY:

- Pre-start-up checklist completed? yes no
If no, perform Pre-Start-up Checklist before starting humidifier.

START-UP PROCEDURE:

The prerequisites for the humidifier filling and contactor pulling in to make steam are as follows:

- Front cover in place and secured with screws yes no
- Water supply valve opened yes no
- Mains disconnect switched on yes no
- Turn On/Off switch on yes no
- On/Off security loop (Terminal 1 and 2) closed. yes no
- Fan security (Terminal 1 and 8) closed yes no

CONTROLS:

- Installed controls match configuration yes no
- Control Setpoint: _____ High Limit Setpoint: _____
- > 3 VDC on terminal 4 (Modulating Humidistat) yes no
or
- Terminal 1 and 2 closed (On/Off Humidistat) yes no

The Humidifier will undergo a self-test when the power is turned on activating the LED's and other internal components.

If the above listed prerequisites are fulfilled the humidifier will start filling the cylinder and begin normal operation.

Note: Most water does not contain enough conductivity for full boil on initial start-up. Units will need to concentrate the water over a time period (hours to days).

REMARKS:

Started by: _____ Date of Start Up: _____/_____/_____

Company: _____

Operation

32	LED Status Lights
32	Selecting a Relative Humidity Setpoint
33	Humidifier Components
34	Description of Components
35	Humidifier Schematic
36	How the Humidifier Works
36	Steam Generation
36	Drains
36	Steam Distribution
37	Steam Line
37	Condensate Return
38	Humidifier Configuration

LED Status Lights

The RH2 user interface includes 2 LED's which provide information about the humidifier status.

Yellow and Green LED Flashing

Indicates there is no request for humidity.

Yellow LED Flashing

Fault detected, humidifier has stopped operating. Count the number of flashes, see Table 8 for info.

Green LED Flashing

Indicates the humidifier is powered but there is not a request for humidity. Security loop (1-2) is open.

Yellow LED On

Indicates that water level is high

Green LED On

Indicates steam is being produced



Figure 27: LED Status Indicator Lights

Yellow LED Steady On

When the yellow LED is steady on (not flashing) it indicates that the high water sensor has interrupted filling of the cylinder. The LED is on for information only and unless it persists for an extended period of time, it does not require any action.



Selecting a Relative Humidity Setpoint

The optimum humidity setpoint depends on the reasons that a space is being humidified. The “ASHRAE Handbook HVAC Applications” recommends specific design relative humidity for specific applications. See also Nortec publication “When You Need Humidity” (Form 124A) for more information on humidity settings.

Health and Comfort - The benefit of humidity is most pronounced for health and comfort in the 40-60% range. A humidity setting of 45-50% is recommended for this purpose to prevent over humidifying.

Temperature Setback - In cold climates it is often necessary to reduce the humidity level in a conditioned environment to prevent build-up of condensation on the inside of exterior walls, windows, and trim. It is highly recommended that the temperature setback function of the Nortec Digital controls be used under these conditions to prevent damage from condensation. The digital control with an outdoor temperature sensor installed will automatically setback the humidity setpoint to correspond with outdoor temperature.

Duct High Limit – The duct high limit is intended to prevent saturation and wetting in duct work at high load conditions. Nortec recommends a setting of 85% for the duct high limit. It may be necessary to reduce this setting if the duct work is very cold or in contact with exterior cold surfaces.

Humidifier Components

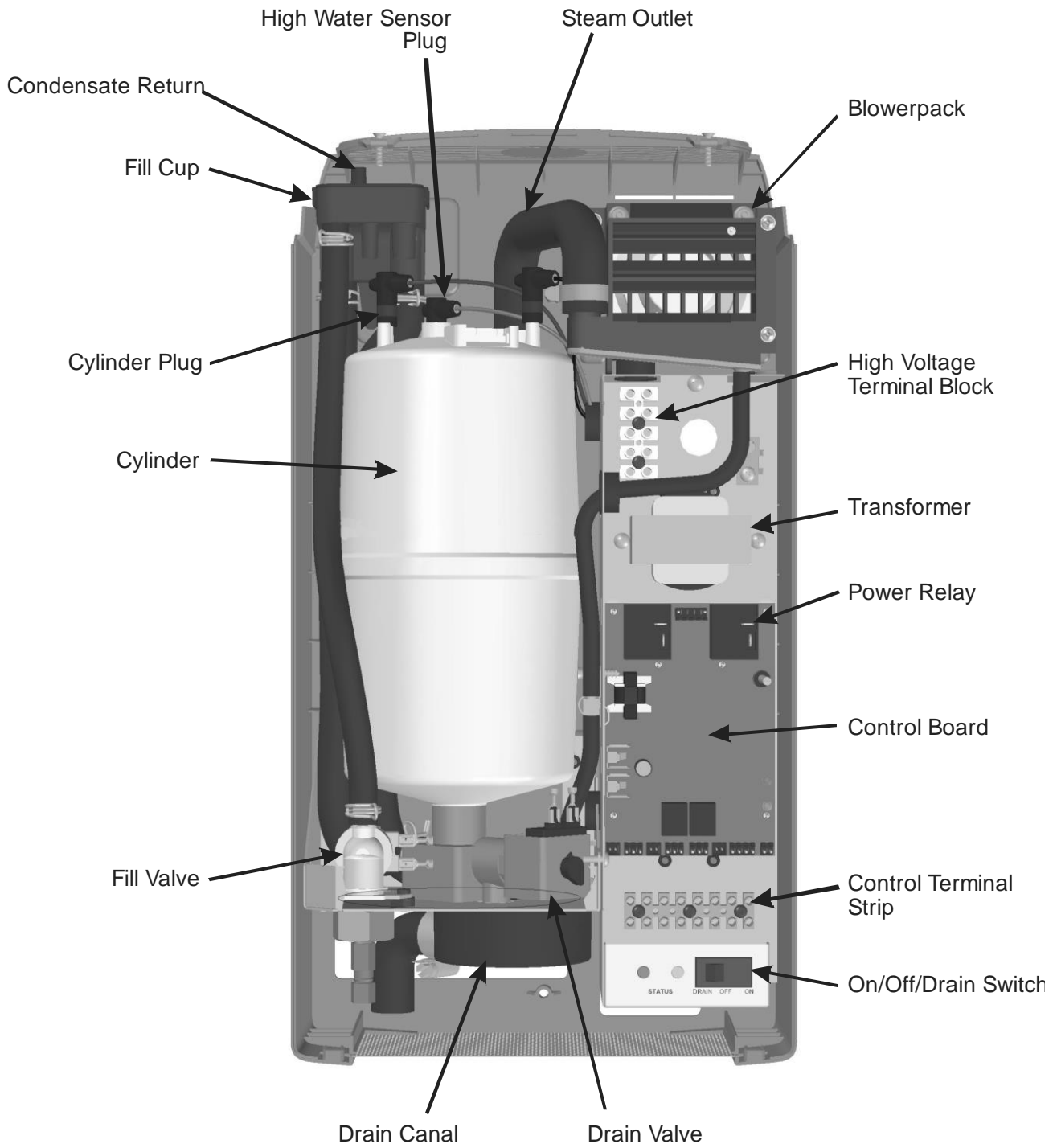

Figure 28: RH2 Humidifier Components

Description of Components

Table 5: Humidifier Components

Component	Function of Component
Blowerpack	Disperses steam generated by the humidifier directly into a space being humidified. Consists of a steam distributor, fan, power supply, and mounting bracket.
Condensate Return	Provides a connection to return condensate to humidifier.
Control Terminal Strip	Terminal strip for connecting external controls to humidifier and interfacing with other equipment.
Cylinder Plug	Power connectors to electrodes in cylinder.
Cylinder	Holds electrodes in water. Current between electrodes generates heat used to generate steam.
Drain Canal	Combines cylinder drain water and fill cup overflow into a single drain outlet.
Drain Valve	Drains water from humidifier.
Control Board	Controls all functions of the humidifier operation and provides input and output connections to humidifier components.
Fill Cup	Provides an air gap for backflow prevention.
Fill Valve	Controls flow of water into humidifier.
High Voltage Terminal Block	Primary power connection from remote disconnect to humidifier.
High Water sensor Plug	Used to detect max water level in cylinder.
On/Off/Drain Switch	Turns power on/off to humidifier controller and drains the cylinder for servicing. Note: Turn off humidifier disconnect to shut off primary power to the humidifier.
Power Relay	Turns on/off power to cylinder electrodes based on a signal from the humidifier's controller (mounted on control board).
Steam Outlet	Connect to steam line with steam hose (shown with steam hose to blower pack).
Transformer	Steps primary voltage down to 24 VAC for the controller and internal components such as the fill valve and drain valve.

Humidifier Schematic

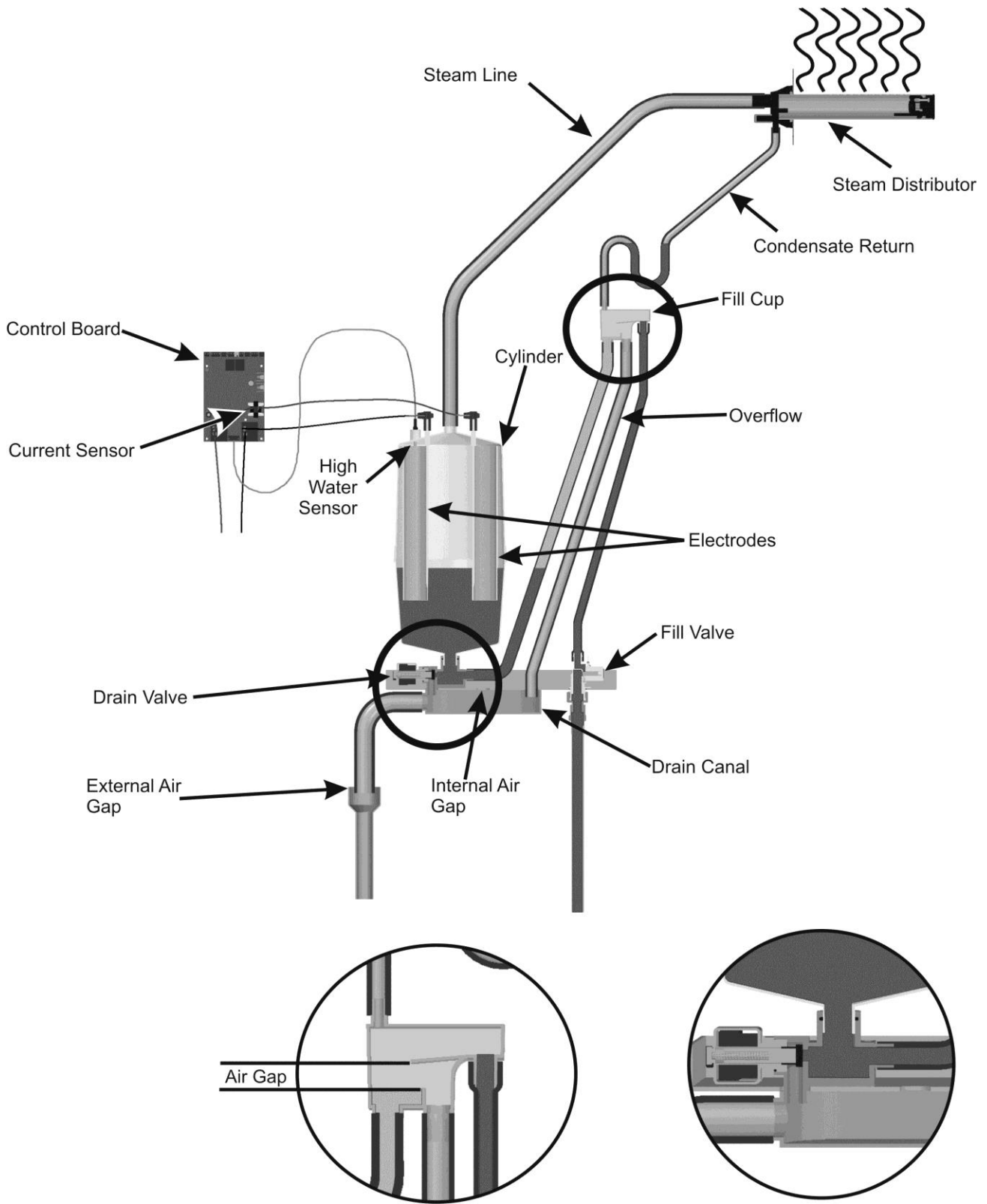

Figure 29: Humidifier Schematic

How the Humidifier Works

The RH2 is an atmospheric steam generator that uses heat generated by electrical current flowing between submerged electrodes to generate steam. The RH2 is designed for air humidification via steam distributor or blower pack.

Steam Generation

- Once the unit receives a demand signal and the safety loop between terminal 1 and 2 is closed, the humidifier closes the contactor and measures the electrical current.
- If the demand is lower than the actual output the inlet valve is kept closed and output is reduced by letting the water level in the cylinder decrease by evaporation.
- If demand is higher than the actual output, after a brief delay the fill valve is activated and water flows into the fill cup. Water from the fill cup flows into the bottom of the cylinder through a hose connected to the drain valve housing.

Note: The cylinder is gravity fed from the fill cup. If backpressure from the steam line is too high it will cause water to back up in the fill cup and flow down the overflow line to the drain.



- As soon as the water in the cylinder comes in contact with the energized electrodes, current flows through the water. The resistance of the water to the electrical charge generates heat and in turn steam. The electrical current (and steam output) increases as the level of water increases, as more of the electrode becomes submerged. The unit continues to fill until the current matches demand or the high water sensor detects a high water level.
- The RH2 repeats the fill and boil down cycle repeatedly to match output to demand.
- Over time minerals in the water will adhere to the cylinder electrodes. The humidifier will automatically fill to a higher water level to maintain full capacity during the life of the cylinder. Eventually because of scale formation it will no longer be possible for the humidifier to reach its full capacity. The RH2 software monitors this condition and, when detected, will stop operating and flash the yellow LED in a repeating sequence of 4 flashes.

Drains

- As steam is produced minerals are left behind, increasing the conductivity of the water. The RH2 patented auto adaptive cycle will monitor the water conductivity and perform drains to maintain the water at optimal conductivity for peak performance.
- The auto adaptive cycle ensures cylinder life is maximized. It does this by keeping the tightest control and most efficient use of water during the entire cylinder life.

Steam Distribution

Steam generated by the humidifier may be introduced into the air in several different ways. The most common method for adding the steam into the air is to mount a steam distributor tube in a supply air duct as shown in Figure 29: Humidifier Schematic. For introducing steam directly into a room humidifier, built-in or remote mounted blower packs may be used see Figure 30: Remote Blower Pack on page 37.

Steam Line

The steam line between the cylinder steam outlet and the distributor serves two purposes: it is used as a conduit to transfer the atmospheric steam from the humidifier to the distributor, as well as providing a means to remove condensate. See steam distributor on page 10 for information on selecting steam lines.

Condensate Return

Whenever steam is distributed condensate is formed in the distribution system. Insulating steam lines is one important way to reduce the amount of condensate formed. Steam lines are sloped so that condensate does not collect in the lines and create a restriction to steam flow. The condensate must be collected and removed from the system so that it does not build up and leak into the duct (or room if blower pack is used). Condensate can be returned to the RH2 fill cup to reduce water waste or can be fed to drain.

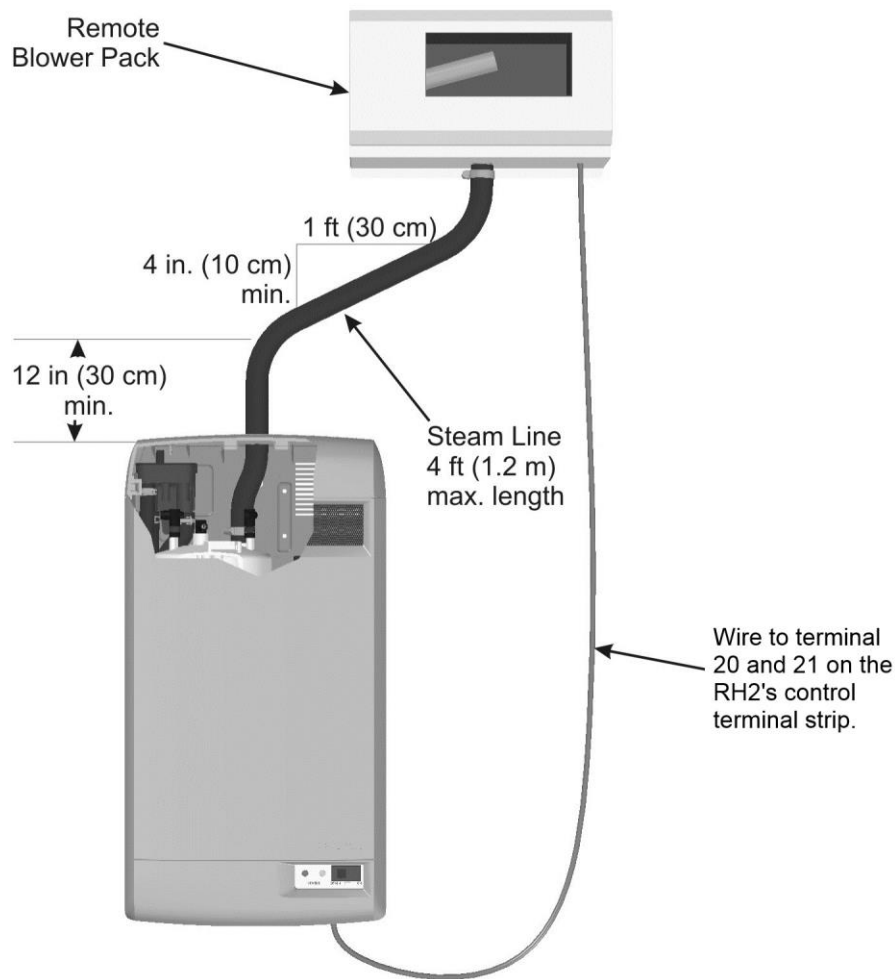

Figure 30: Remote Blower Pack

Humidifier Configuration

The RH2 is factory configured to operate under most conditions without the need for any changes to its configuration. If required, several settings can be made using jumpers on the RH2's control board. The output of the RH2 can also be reduced by using a potentiometer on the RH2's control board. See Figure 31: RH2 Control Board Jumpers for location of jumpers and the capacity adjustment potentiometer.

Note: Nortec recommends not making any configuration changes unless they are required and that any changes to the RH2 settings be performed by a qualified technician.

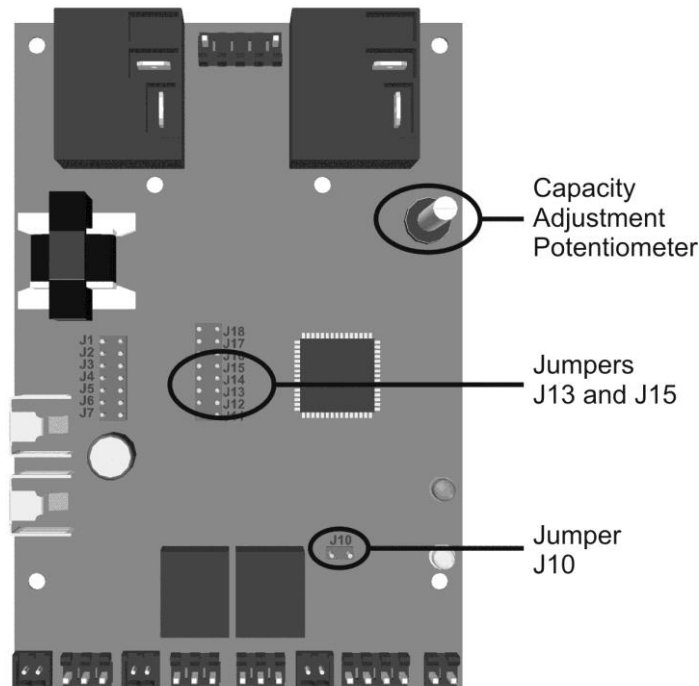

Figure 31: RH2 Control Board Jumpers

Caution: Never adjust jumpers other than those listed in this section. Other jumpers are factory set and must not be changed.



Capacity Adjustment

The capacity adjustment potentiometer can adjust the capacity of the humidifier between 100% and 30% of its rated output. (Factory setting = 100% output).

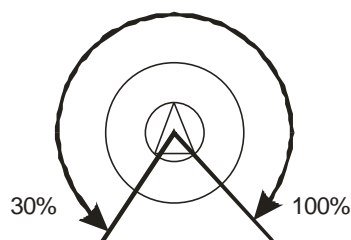

Figure 32: Capacity Potentiometer Adjustment

On/Off or Modulating Control (J10)

The RH2 output can be controlled by either an On/Off or a modulating humidistat. To set the RH2 to operate with a modulating humidistat, remove Jumper J10. (Factory setting = jumper Installed , On/Off operation)

J10 Removed– Modulating operation, the controller monitors the demand signal on terminal point 4 of the control terminal strip and adjusts humidifier output to match it.

J10 Installed - The RH2 is configured for On/Off operation. The controller will ignore any modulating signals even if they are connected.

Modulation Offset (J13)

The RH2 controller can be configured to work with a modulating humidistat with 4-20 mA or 2-10 VDC output. Modulation offset can be configured with jumper 13. (Factory setting = Jumper Removed, 0-10 VDC or 0-20 mA control signal)

J13 Removed – Controller is configured for a 0-10 VDC or 0-20 mA control signal.

J13 Installed – Controller is configured for a 2-10 VDC or 4-20 mA control signal.

For mA control a 500Ω register is required between terminals 3 and 4 on the low voltage control terminal.

Table 6: Control Jumper Configuration

Resulting Control	J10	J13
On/Off	Installed	No Affect
Modulating 0-10 VDC or 0-20 mA	Removed	Removed
Modulating 2-10 VDC or 4-20 mA	Removed	Installed

Ground Fault Interrupt (GFI) (J15)

Ground current leakage can occur when the humidifier performs drains. With jumper J15 the RH2 can be configured to turn off the power to the electrodes whenever a drain takes place.

J15 Removed – The power relay is on during drains to control cylinder water concentration.

J15 Installed – The power relay is turned off during drains to control cylinder water concentration.

Maintenance and Servicing

41 Required Maintenance

- 41 Cylinder Spent Fault
- 41 Replacement Cylinder
- 42 Removing the Cylinder
- 43 Drain Valve Cleaning
- 44 Installing the New Cylinder

45 Extended Shutdown

- 45 Starting After Extended Shutdown

46 RH2 Maintenance Checklist

Required Maintenance

The RH2 humidifier has been designed to require very little maintenance. Regular maintenance consists of checking the humidifier to ensure it is in good condition, replacing the cylinder when the software advises that the cylinder is spent and cleaning out the drain valve whenever the cylinder is replaced.

Cylinder Spent Fault

When the cylinder is spent the RH2 will stop operating and the yellow LED will flash in a repeating pattern of 4 flashes. See Table 8: Troubleshooting RH2 Faults on page 51 for more information on other flash sequences. At this time the cylinder must be replaced.

The steam cylinder is disposable and must be replaced at end of cylinder life. Cylinder life is dependent on water supply conditions and humidifier usage.



Caution: Failure to replace the cylinder at the end of cylinder life will result in improper operation and may result in damage to the humidifier. Nortec is not responsible for any damages resulting from, or attributed to, the failure to replace a spent cylinder (see Manufacturer's Warranty).



Note: Nortec recommends keeping a replacement cylinder in stock throughout the humidification season. This will prevent possible downtime when the humidifier reports cylinder end of life.

Replacement Cylinder

The label on the existing cylinder identifies the cylinder type in its top left corner. When ordering a cylinder always quote the three or five digit model number on the label, the humidifier's serial number and the humidifier's voltage. Serial number and voltage are located on the specification label on the left side of the humidifier.

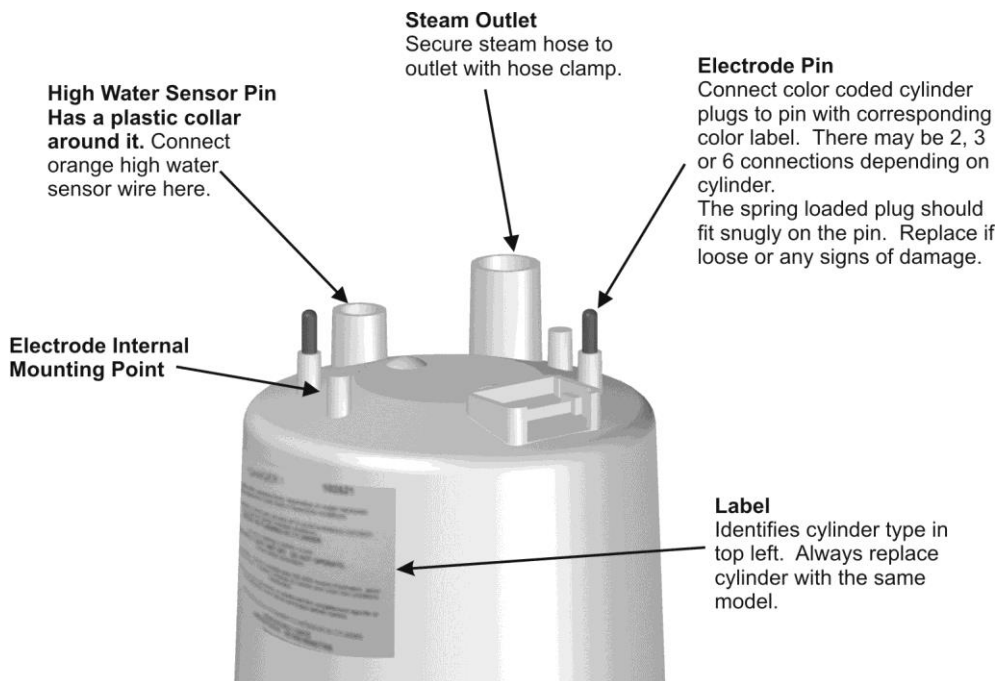

Figure 33: RH2 Cylinder

Removing the Cylinder

Warning

- Disconnect main power at the external disconnect before any servicing.
- The inside of the humidifier cabinet contains high voltage components and wiring. Access should be limited to authorized personnel.



- 1** Drain the existing cylinder by switching the On/Off/Drain switch to the Drain position. Let the humidifier drain until no more water is flowing out to drain (usually not more than 10 minutes).
- 2** Turn the humidifier On/Off/Drain switch to off.
- 3** Close supply water shut off valve.
- 4** Turn off power to the humidifier with the external disconnect.
- 5** Remove the two screws securing the front cover.
- 6** Remove the cylinder plugs from the cylinder pins by pulling vertically.
- 7** Using a flat screwdriver loosen the hose clamp where the hose is connected to the cylinder.
- 8** Tip the top of the cylinder forward to pivot it out of the steam hose. When free of steam hose lift the cylinder out.

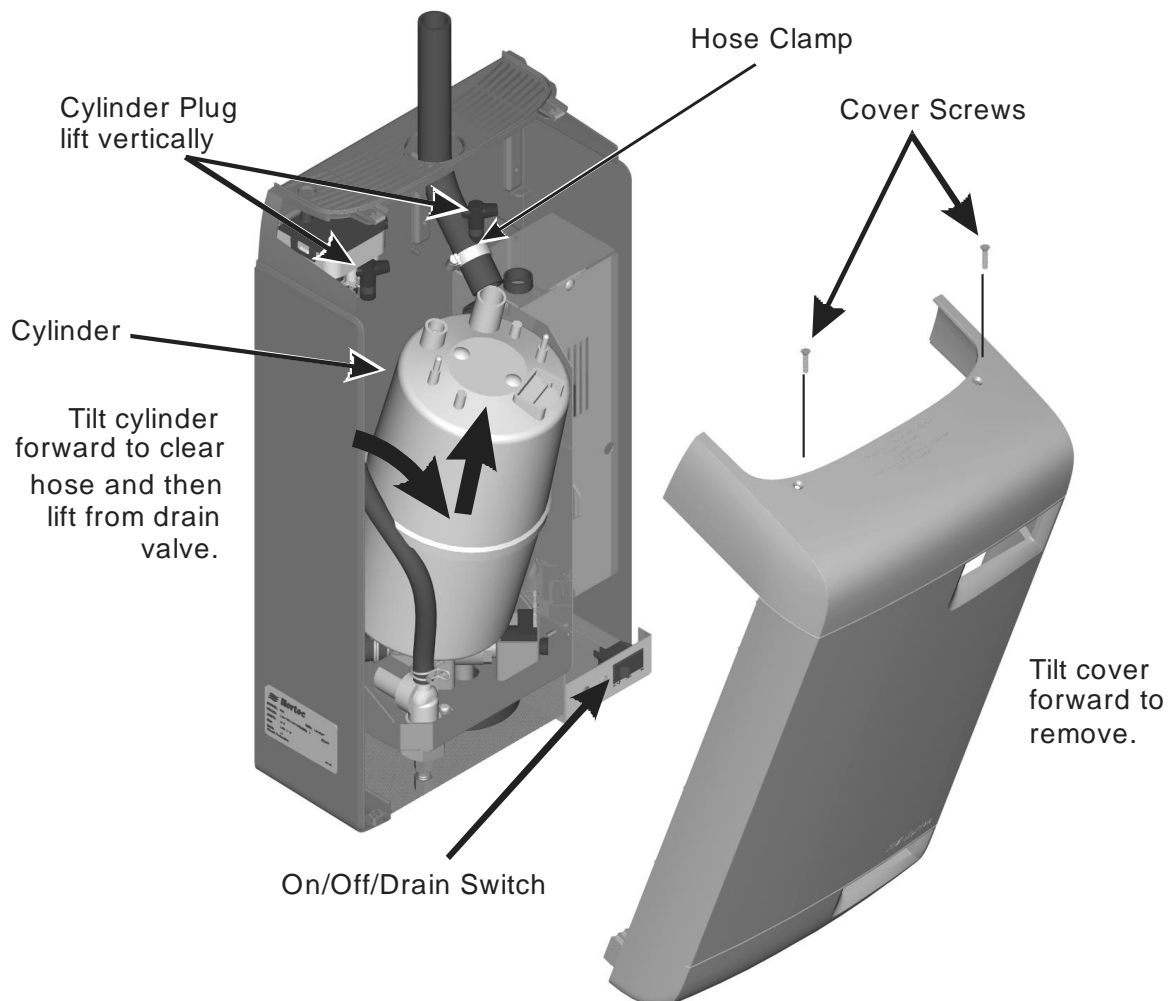

Figure 34: Cylinder Removal

Drain Valve Cleaning

Always clean the drain valve before installing a new cylinder. Scale from the spent cylinder may have fallen into the drain valve and could prevent its proper operation. To properly clean the drain valve it must be removed and disassembled.



Note: Be sure to reattach the green ground wire to reduce the risk of electrical shock.

- 1 Disconnect spade terminals from the drain valve.
- 2 Remove the screw holding the green ground wire and the two screws holding the valve to the drain pan.
- 3 Squeeze the tabs of the spring clamp holding the hose to the drain valve and slide it up the hose. Pull hose from drain valve. Lift the drain valve from the drain pan.
- 4 Unsnap red coil cap on solenoid and remove the solenoid from the valve.
- 5 Loosen brass nut holding actuator to plastic housing with a wrench and disassemble actuator.
- 6 Clean actuator components and valve housing (inlet port, outlet port, and cylinder port). Put new o-ring that was supplied with new cylinder into valve.
- 7 Reassemble actuator making sure tapered end of spring is oriented as shown in Figure 36. Tighten brass nut 1/4 turn past hand tight.
- 8 Clean out end of hose and reattach to valve. Slide hose clamp back in place and place valve into drain pan.
- 9 Secure valve with 2 screws and attach green ground wire to solenoid.

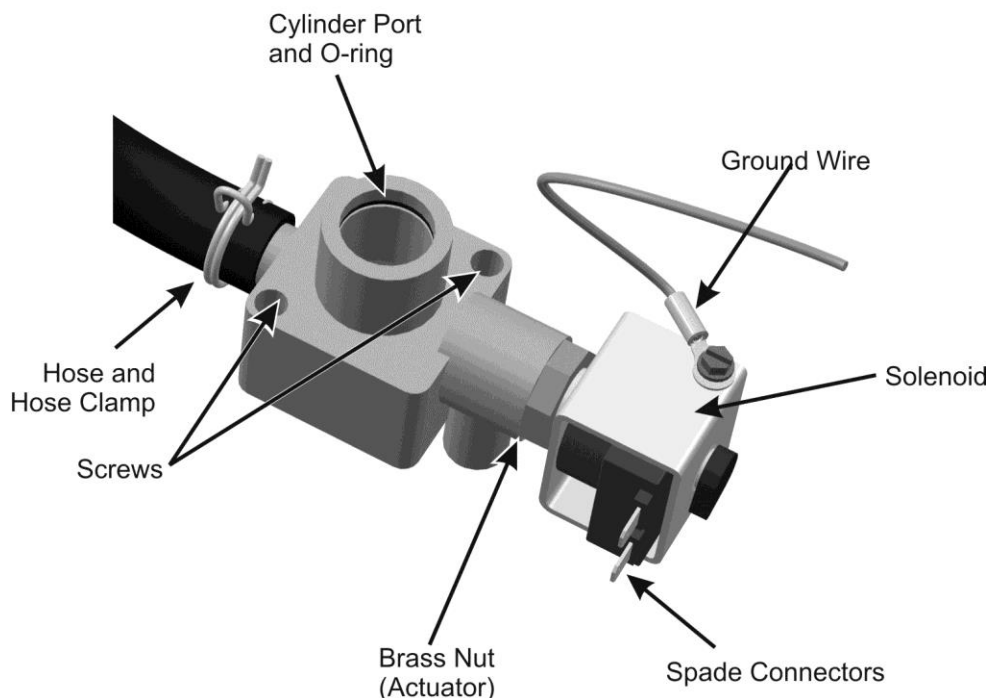

Figure 35: Drain Valve

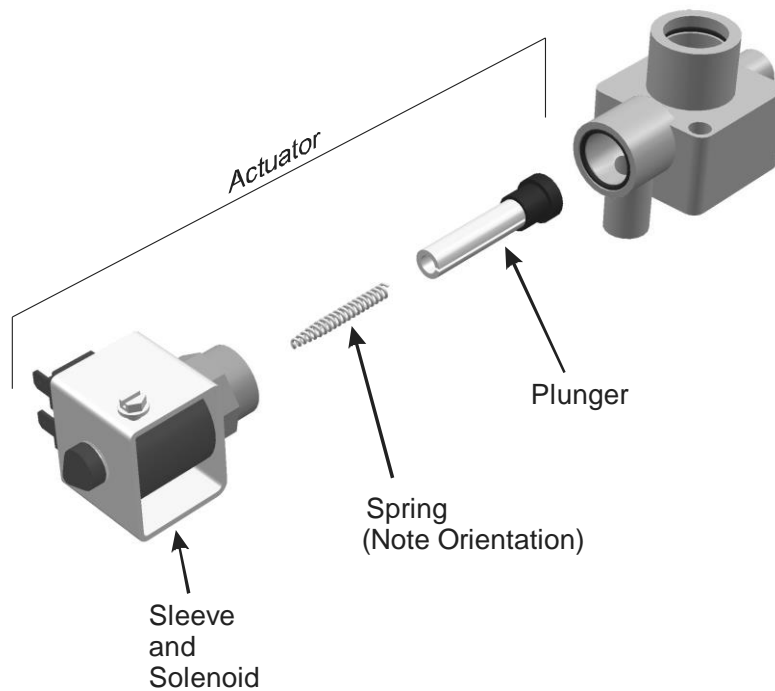

Figure 36: Drain Valve Actuator Assembly

Installing the New Cylinder

CAUTION: Make sure the new cylinder is the same model as the one that was removed. Model number is on top left corner of cylinder label.



- 1** Insert cylinder into drain valve. Tilt cylinder forward and fit end of steam hose to steam outlet. Tip cylinder back into place.
- 2** Tighten hose clamp being careful not to over tighten and crush the plastic cylinder steam outlet.
- 3** Attach color-coded cylinder plugs to the corresponding color-coded cylinder pin. Push down completely. Connect high water sensor plug. Spring-loaded plugs should fit snugly onto the cylinder pin. Replace if they are loose or damaged.
- 4** Replace the humidifier cover and secure with two screws.
- 5** Turn on power to humidifier with the external disconnect.
- 6** Open supply water shut off valve.
- 7** Turn the humidifier On/Off /Drain switch to On.

Extended Shutdown

Should it be required to disconnect power to the humidifier for a period of extended shut-down, always drain the cylinder first.

- 1 Switch the On/Off/Drain Switch to the Drain position.
- 2 Wait until the humidifier is completely drained (usually takes less than 10 minutes).
- 3 Turn the On/Off /Drain switch to the off position.
- 4 Shut off power to the humidifier with the external disconnect.
- 5 Close the supply water shut-off valve.



Note: As long as the RH2 is powered, it will automatically drain the cylinder when there has not been a call for humidity for an extended period of time. This feature will reduce or prevent the possibility of corrosion of the electrodes and the accumulation of algae and bacteria growing in the cylinder. The cylinder will remain empty until there is a call for humidity at which time the fill valve will open and refill the cylinder. The unit will go through its normal process for optimum operation.

Starting After Extended Shutdown

- 1 Check to see the humidifier has not been damaged and the installation has not been altered. Refer to the Chapter on Start Up.
- 2 Turn on the power to the humidifier with the external disconnect.
- 3 Turn the On/Off/ Drain switch to the Drain position.
- 4 Wait until there is no water flowing to drain. It usually takes less than 10 minutes.
- 5 Follow the start up procedure in the chapter on Start Up.

RH2 Maintenance Checklist

Model #: _____

Serial #: _____

Tag: _____

Cylinder #: _____

CHECK CYLINDER

- Cylinder spent), yellow LED flashing 4 times in sequence.
(If Yellow LED is On and cylinder is not new then cylinder will have to be replaced soon.)

REPLACE CYLINDER

- Cylinder drained.
- Disconnect open, On/Off/Drain switch off, water shut off valve closed, cover removed.
- Cylinder removed
- Drain valve removed / cleaned / new O-Ring
- Drain valve installed / ground wire attached.
- New Cylinder Installed New cylinder model # _____
(Should be same as removed cylinder)
- Cylinder plug colors match cylinder dots.
- Cylinder plugs snug and in good condition.
- High Water Sensor plug snug and in good condition.
- Cover replaced, water shut off valve open, On/Off /Drain switch On, Disconnect Closed

SYSTEM CHECK

- Yellow Led flashing? No Yes Flash Sequence? _____
(See Troubleshooting Chapter for actions if yellow LED is flashing)
- Cylinder plugs snug and in good condition.
- Electrical wiring not loose and in good condition,
- Steam hoses and steam lines in good condition / No kinks in hose,
- No Signs of water leaking around humidifier, steam line, condensate returns,

Inspected by: _____ Date of inspection: ____/____/____

Company: _____

Troubleshooting

48 Organization of Troubleshooting Chapter

48 Troubleshooting Requirements

49 General Troubleshooting

49 Humidifier

50 Steam Distributors

50 Blower Pack

50 Digital Humidistat

51 RH2 Faults

51 LED Flash Sequence

51 Clearing a Fault

53 RH2 Wiring Diagram

54 Exploded View and Spare Parts List

58 Warranty

Organization of Troubleshooting Chapter

The troubleshooting chapter is broken down into 2 sections.

General Troubleshooting	Deals with troubleshooting incorrect humidifier operation, steam line and plumbing issues without any control software faults.
Humidifier Warnings and Faults	Deals with faults that are generated by the humidifier control software.

CAUTION: Be aware, when troubleshooting, that the humidifier is powered by high voltage and familiarity with both good practices and wiring of the humidifier is recommended. Any troubleshooting that requires opening the cabinet should be done by qualified personnel.



NOTE: Most humidifier faults are not caused by faulty equipment but rather by improper installation. A complete fault diagnosis always involves a thorough examination of the entire system. Often, the steam hose connection has not been properly executed, or the fault lies with the humidity control system.



Troubleshooting Requirements

- Ensure the installation meets the installation requirements outlined in the Installation Chapter of this manual.
- Familiarize yourself with the operation of the humidifier by reading the Operation Chapter of this manual.
- Wiring diagram for specific for your humidifier is installed on the inside of the humidifier door. A generic copy of the RH2 wiring diagram is also included at the end of this chapter for reference purposes.
- When contacting your local representative or Nortec for troubleshooting assistance, please ensure the serial number has been obtained for reference purposes.

General Troubleshooting

The following section provides general guidelines for troubleshooting the RH2 humidifier and auxiliary components. For detailed troubleshooting information refer to the manuals that were provided with the auxiliary equipment and to Table 8: Troubleshooting RH2 Faults after in this chapter.

Table 7: General Troubleshooting

Symptom	Cause	Corrective Action(s)
Nothing happens when On/Off switch is turned on.	1 Fuse blown	1 Check inline fuse between transformer and control board.
	2 Incorrect Voltage	2 Check voltage against spec label and correct.
	3 Step Down Transformer not outputting 24VAC	3 Replace the transformer
	4 Incorrect primary power jumper	4 Check that jumper on high voltage terminal block is connected between P and terminal corresponding to supply voltage.
Humidifier will not humidify or not reaching RH2 setpoint	1 Safety loop open	1a Check if there is 24 VAC at terminal 2. 1b Check wiring and operation of On/Off devices connected to terminal 1 and 2. 1c Check jumper is installed in air proving safety loop, terminal 1 and 8.
	2 No demand signal	2 Check voltage between terminal 3 and 4. For demand configuration 35% of full-scale signal must be present for humidifier to start.
	3 Not configured correctly for On/Off or modulating control	3 Check that J10 on control board is removed for modulating control and installed for On/Off control.
	4 Capacity has been manually limited	4 Check Manual Capacity adjustment potentiometer. Clockwise increases capacity.
	5 Low conductivity water	5 Check if yellow LED is on. If operated on low conductivity water it may take several hours for the RH2 to reach full output capacity. This is normal. During this time the humidifier will not perform any drains and the conductivity of the water in the cylinder will increase.
	6 Incorrect configuration (Modulating or On/OFF)	6 Check J10 on control board, remove if a modulating humidistat is being used.
	7 No airflow in duct	7 Check that humidifier fan enable (terminals 19-20) are properly wired to furnace. Check air proving wired to terminal 8.
Humidifier has faulted and yellow LED is flashing	1 Software has detected an abnormal condition	1 Refer to Table 8: Troubleshooting RH2 Faults.

Steam Distributors

Symptom	Cause	Corrective Action(s)
Distributor spitting out water	1 Distributor not level	1 Use support at end of distributor to ensure it is level.
	2 "P" Trap too close to distributor	2 "P" Trap must be a minimum of 12 in (30 cm) below the distributor to ensure flow. Relocate if required.
	3 Condensate line not sloped sufficiently	3 Sufficient slope to ensure flow is required. Reinstall if required.
	4 Trap blocked	4 Check that water flows through trap. Clear out if blocked.
	5 Steam line not insulated	5 If steam line is long, condensate build up could overload distributor condensate port. Insulate line to improve efficiency and install additional condensate traps as required.
	6 Incorrect steam line installation	6 Check that steam line has been installed with condensate traps and slope per installation instructions on page 12.
Condensation in duct	1 Installation clearances not observed	1 Refer to distributor installation manual for required clearances. Relocate distributor if required.
	2 Design conditions changed	2 Check supply air temperature and humidity to determine if conditions have changed.
	3 High limit not functioning	3 Check setting and operation of high limit. Replace if defective.

Blower Pack

Symptom	Cause	Corrective Action(s)
Blower not operating	1 No power to blower pack	1a Check power connection to blower pack. 1b Ensure unit is humidifying. The blower will not operate if the humidifier is not generating steam.

Digital Humidistat

Symptom	Cause	Corrective Action(s)
Humidistat Reading incorrectly	1 Sensor out of calibration	1 Check reading against known reliable instrument. If out of calibration it can be field calibrated $\pm 10\%$. Refer to humidistat documentation for calibration instructions.

RH2 Faults

The self-diagnostic system built into the RH2 is continually monitoring the operation of the humidifier. When an abnormal condition occurs that cannot be self-corrected by the software the RH2 will turn off power to the cylinder, drain the cylinder, and annunciate the fault using the yellow status LED.

LED Flash Sequence

To differentiate between different fault conditions the yellow LED is flashed in different sequences. Table 8 lists the fault sequences that can be displayed, their meaning, possible cause and suggested corrective actions.

Clearing a Fault

- Check the flash sequence against the list of fault messages and take any necessary actions to correct the cause(s) as outlined in Table 8: Troubleshooting RH2 Faults.
- Power cycle the humidifier with the On/Off switch waiting 10 seconds between turning it off and on. If an externally powered 0-10V controller is used, it must be turned off prior to clearing the fault.

Table 8: Troubleshooting RH2 Faults

Yellow LED	System Detected	Cause	Corrective Action(s)
1 flash	Excess Current Current has exceeded 130% of max	1 Drain blocked water over concentrated	1 Clean the drain line
		2 Drain solenoid not energized, water over concentrated	2 Check and correct wiring to drain valve.
		3 Filling too fast, fill valve damaged and leaking	3 Replace the fill valve
		4 Filling too fast, wrong fill valve	4 Check for correct fill valve in parts list, replace if incorrect
		5 Water supply too conductive	5a Contact Nortec representative for recommendation on alternate cylinder 5b Change the water supply
		6 Humidifier short cycling	6a Check if high limit or other On/Off control is cycling On/Off in less than 5 minutes. Check location and setting of high limit. 6b Reduce the output by turning down the capacity potentiometer.
		7 Wrong cylinder installed	7 Install correct cylinder model
		8 Cylinder Spent but not detected by software	8 Replace the cylinder (see maintenance chapter)
		9 Condensate from other source	9 Remove condensate returns other than from steam line.
		10 Back pressure	10 Eliminate back pressure

Table 8: Troubleshooting RH2 Faults (Continued)

Yellow LED	System Detected	Cause	Corrective Action(s)
2 flashes	<p>No Current Fill valve activated for long time but high water level not reached. Fill should be faster than 1” per minute.</p>	1 Drain valve leaking or stuck open	1 Clean drain valve or replace (see maintenance chapter)
		2 Water shut off valve closed	2 Open shut off valve
		3 Fill Valve strainer blocked	3 Clean out strainer on fill valve inlet.
		4 High system back pressure	4a Check for kinked hose 4b Check for proper condensate removal (see installation chapter) 4c Install fill cup extension
		5 High water sensor not connected	5 Check that cylinder plug with white marker is connected to short electrode with a plastic well around it and to control board.
		6 Low water conductivity	6a Check if potable water supplied to unit, not treated water (RO or DI) . 6b Check conductivity of water. If less than 150 µS/cm. 6c Add 1/4 teaspoon of salt to fill cup and restart unit.
3 flashes	<p>No Current, High Water Water level at top of cylinder with no current</p>	1 Primary wire not looped through current transformer.	1 Open disconnect, rewire primary wire through current transformer.
		2 High water sensor plug is on an electrode pin.	2 Install high water sensor plug on cylinder pin with shroud around it.
		3 Cylinder plugs installed incorrectly	3 Check that cylinder plugs colors match markers next to electrodes on cylinder and that white marked cylinder plug is connected to short electrode located in plastic well.
4 flashes	<p>Cylinder Spent Electrodes covered with scale.</p>	1 Cylinder electrodes are covered with scale and humidifier cannot meet demand	1 Replace cylinder with same model number (see maintenance chapter). In order to clear “spent cylinder” fault codes, externally powered modulating controllers will have to be turned off before power cycling the unit.

RH2 Wiring Diagram

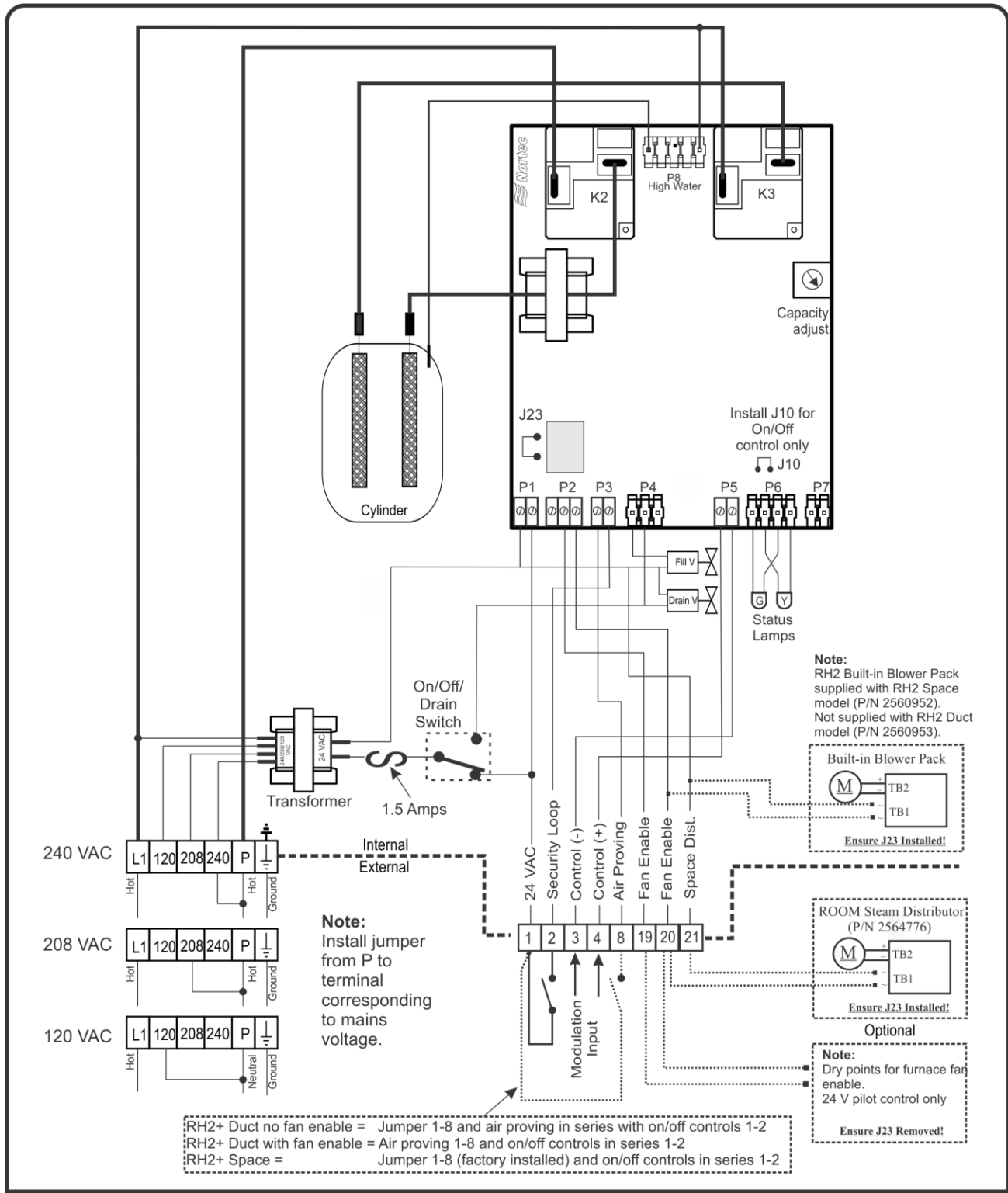

RH2+ humidifier 120/208/240 Vac

Wiring Diagram

2568049 Revision: D Date: 07/09/2015

Exploded View and Spare Parts List

RH2+ Spare Parts

The Nortec residential humidifier model should be confirmed.

The following spares parts are for **RH2+** models only:

Nortec Part No.	Description
2560953	RH2+ Duct, 10lbs/hr, 120/208/240V 1P
2560952	RH2+ Space, 8lbs/hr, 120/208/240V 1P

Spare parts **RH** and **RH2** models can be found in RH2 manual 2549509.

Go to www.humidity.com to download RH2 manual 2549509.

Nortec Part No.	Description
2548759	RH Duct, 10lbs/hr, 120/208/240V 1P
2548758	RH Space, 8lbs/hr, 120/208/240V 1P
2548005	RH2 Duct, 10lbs/hr, 120/208/240V 1P
2548004	RH2 Space, 8lbs/hr, 120/208/240V 1P

RH2+ Spare Parts

The following spares parts are for RH2+ models only:

Nortec Part No.	Description
2560953	RH2+ Duct, 10lbs/hr, 120/208/240V 1P
2560952	RH2+ Space, 8lbs/hr, 120/208/240V 1P

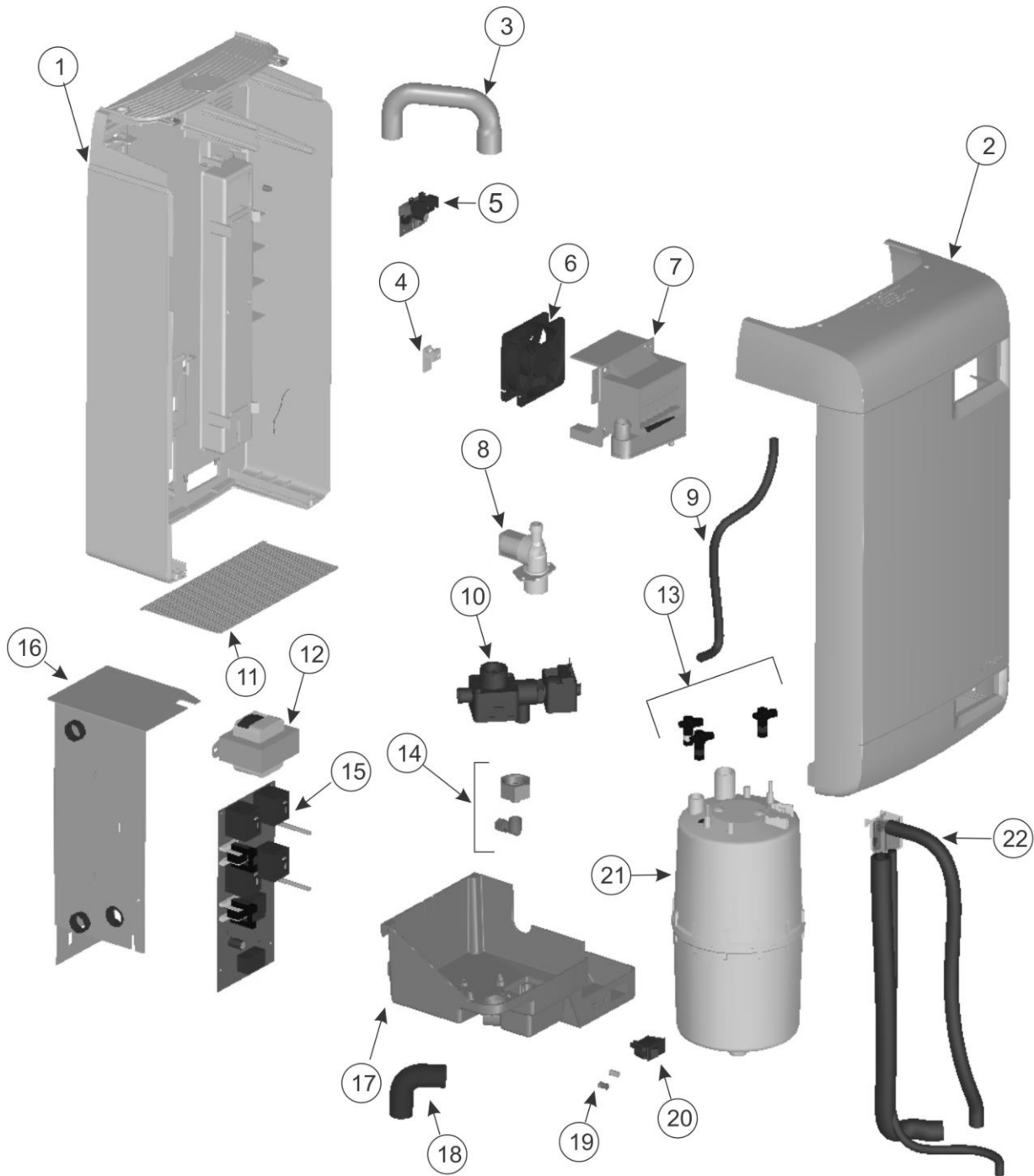

Figure 37: RH2 Spare parts

RH2+ Spare Parts

The following spares parts are for RH2 models only:

Nortec Part No.	Description
2560953	RH2+ Duct, 10lbs/hr, 120/208/240V 1P
2560952	RH2+ Space, 8lbs/hr, 120/208/240V 1P

Table 9: RH2 Spare Parts List

Item	Nortec Part No.	Description
1	Reference	RH2 DUCT Back Cover or RH2 SPACE Back Cover
2	2560780 or 2547403	RH2 DUCT Front Cover or RH2 SPACE Front Cover
3	2549654	RH2 Space Preformed Hose
4	1323020	Ground Clamp
5	2548008	RH2 SPACE Power Supply
6	2548314	RH2 SPACE Fan
7	2548683	RH2 SPACE Distributor
8	2573515	Fill Valve
9	2568368	RH2 SPACE Condensate Hose
10	1456000	Drain Valve Assembly
11	2548313	Optional Bottom Cover
12	2562415	Transformer Multi-tap 120/208/240V
13	2547964	Cylinder Plug Kit
14	1639011	Elbow/Compression Fitting Assembly
15	2568048 or 2568047	PCB RH2+ DUCT 10 lbs/hr or PCB RH2+ SPACE 8 lbs/hr
16	Reference	Electrical Backplate
17	Reference	Drain Pan
18	2547998	Preformed Drain Hose
19	1583008	LED Lens
20	1323097	Rocker Switch
21	1519002	Cylinder 202
22	2569903	Fill Cup Assembly
Not Shown	1583126	1.50A Fuse

Warranty

Nortec Humidity Inc. and/or Nortec Humidity Ltd. (hereinafter collectively referred to as THE COMPANY), warrant for a period of two years after installation or 30 months from manufacturer's ship date, whichever date is earlier, that THE COMPANY's manufactured and assembled products, not otherwise expressly warranted (with the exception of the cylinder), are free from defects in material and workmanship. No warranty is made against corrosion, deterioration, or suitability of substituted materials used as a result of compliance with government regulations.

THE COMPANY's obligations and liabilities under this warranty are limited to furnishing replacement parts to the customer, F.O.B. THE COMPANY's factory, providing the defective part(s) is returned freight prepaid by the customer. Parts used for repairs are warranted for the balance of the term of the warranty on the original humidifier or 90 days, whichever is longer.

The warranties set forth herein are in lieu of all other warranties expressed or implied by law. No liability whatsoever shall be attached to THE COMPANY until said products have been paid for in full and then said liability shall be limited to the original purchase price for the product. Any further warranty must be in writing, signed by an officer of THE COMPANY.

THE COMPANY's limited warranty on accessories, not of the companies manufacture, such as controls, humidistats, pumps, etc. is limited to the warranty of the original equipment manufacturer from date of original shipment of humidifier.

THE COMPANY makes no warranty and assumes no liability unless the equipment is installed in strict accordance with a copy of the catalog and installation manual in effect at the date of purchase and by a contractor approved by THE COMPANY to install such equipment.

THE COMPANY makes no warranty and assumes no liability whatsoever for consequential damage or damage resulting directly from misapplication, incorrect sizing or lack of proper maintenance of the equipment.

THE COMPANY makes no warranty and assumes no liability whatsoever for damage resulting from freezing of the humidifier, supply lines, drain lines, or steam distribution systems.

THE COMPANY retains the right to change the design, specification and performance criteria of its products without notice or obligation.

U.S.A.
2700 90th St.
Sturtevant, WI 53177

835 Commerce Park Dr.
Ogdensburg, NY 13669-2209

CANADA
2740 Fenton Road
Ottawa, Ontario K1T 3T7

TEL: 1.866.NORTEC1
EMAIL: nortec@humidity.com
WEBSITE: www.humidity.com

