

Application

Proportional pneumatic actuator with 20 in.² (129 cm²) effective area used to control damper and air valves in heating, ventilating, and air conditioning systems. MK2-71X1 is used for high temperatures.

Features

- Rugged cast aluminum body.
- Completely enclosed spring.
- Long lasting rolling diaphragms.
- Heavy duty mounting plate included.

Applicable Literature

- Environmental Controls Cross-Reference Guide, F-23638
- Environmental Controls Reference Manual, F-21683
- Pneumatic Products Catalog, F-27383
- AK-42309-500 Positive Positioning Pneumatic Relay, F-22909

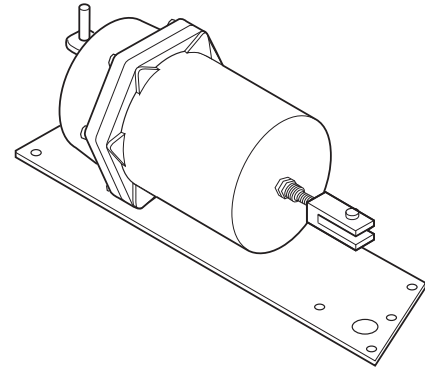

SPECIFICATIONS

Construction

Housing: Die cast aluminum.

Diaphragm: Replaceable beaded molded neoprene.

Diaphragm (MK2-71X1 only): Replaceable beaded molded silicone.

Mounting: Any position.

Dimensions of Actuator: 17-5/8 x 7-3/4 x 7-5/8 in. (448 x 197 x 194 mm).

Mechanical

Stroke: Nominal 4-1/2 in. (114 mm), adjustable 4 to 5 in. (102 to 127 mm).

Nominal Damper Area: Actuator sizing should be done in accordance with damper manufacturer's specifications.

Start Point: Adjustable, see Table-1.

Spring: Retracts actuator crank arm on loss of air pressure.

Maximum air pressure: 30 psig (207 kPa).

Environment

Ambient Temperature Limits:

Shipping, -40 to 160°F (-40 to 71°C).

Operating, -20 to 160°F (-29 to 71°C).

Ambient Temperature Limits (MK2-71X1 only):

Shipping, -40 to 250°F (-40 to 121°C).

Operating, -20 to 250°F (-29 to 121°C), for 30 minute exposure 450°F (232°C).

Air Connections: 1/8" FNPT.

Air Connections (MK4-7100 Series only): Barbed fittings for 1/4" OD poly tube.

Table-1 Model Chart for Actuators.

TAC Model No.	Nominal Operating Range	Starting Pressure Adjustable	Maximum Force ^c				Nominal Torque ^b Proportional Control ^c		
			Return Stroke	Power Stroke			15 psi Supply Dual Press. System	15 psi Supply Single Press. System ^d	20 psi Supply Single or Dual Press. System ^d
			Based on 1.5 psi Pressure to Actuator	15 psi Supply Dual Press. System	15 psi Supply Single Press. System ^d	20 psi Supply Single or Dual Press. System ^d			
psi	psi	lb.	lb.	lb.	lb.	lb. -in.	lb. -in.	lb. -in.	
MK-7101 MK4-7101 ^a	3 to 8	3 ± 0.5	30	110	140	240	67.5	67.5	67.5
MK-7121 MK4-7121 ^a	8 to 13	8 ± 0.5	130	10	40	140	22.5	90	293

^a Factory installed positive positioner (AK-42309-500) start point adjustable 1 to 12 psi (7 to 83 kPa) with span adjustable 2 to 13 psi (14 to 90 kPa).

^b Nominal torque for actuators without positioner is based on 1.5 psi (10 kPa) pressure change at the actuator.

^c Force and torques based on factory set stroke and starting pressure.

^d Adjust pressure reducing valve so that listed pressures are available at the actuator.

Accessories

AK-42309-500 Positive positioner and linkage (do not use with MK2-71X1; positive positioner does not meet temperature rating of MK2-71X1)

AM-301 90° angle mounting bracket

AM-530^a Crank arm for 1/2 in. diameter damper shaft holes for 4-1/2 in. stroke

AM-532 Frame mounting kit

AM-538 Actuator brace kit

AM-542 Rod end connector for 5/16 in. (10 mm) rod^b

AM-543 Actuator shaft extension

Tool-95 Pneumatic calibration tool kit

^a Required to connect damper actuator to damper shaft.

^b Maximum length of 5/16 in. (10 mm) rod which can be used with AM-542, 15 in. (381 mm).

INSTALLATION

Inspection

Inspect the package for damage. If damaged, notify the appropriate carrier immediately. If undamaged, open the package and inspect the device for obvious damage. Return damaged products.

Requirements

- Piping diagrams
- Training: Installer must be a qualified, experienced technician
- Appropriate accessories

Caution:

- Do not exceed the ratings of the device(s).
 - Avoid locations where excessive moisture, corrosive fumes, or vibration is present.
-

MOUNTING

Preparing Damper for Frame Mounting of Actuator

Refer to Figure-16 for mounting hole locations and mounted actuator dimensions. Refer to Figure-1, Figure-2, and Figure-3 for preparing the damper for a typical bolt on bracket mounting (AM-532).

Note:

Notched blade next to operating blade is required for clearance of clevis and leaf connector.

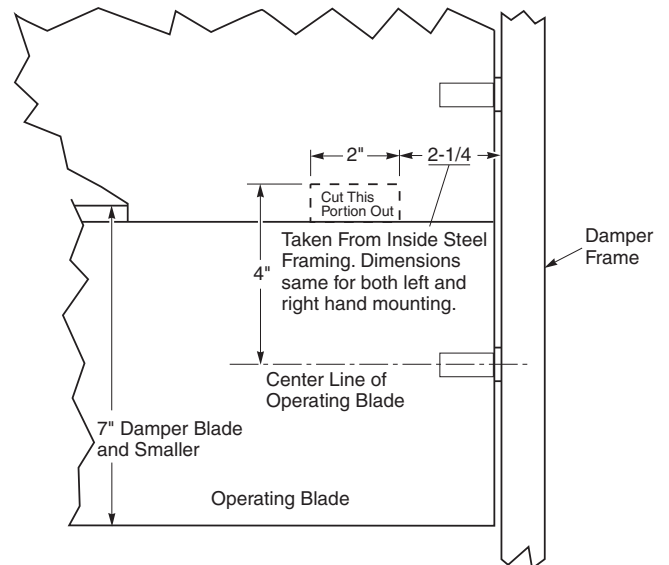

Figure-1 Bracket Mounting for Dampers with Blades 7" or Smaller.

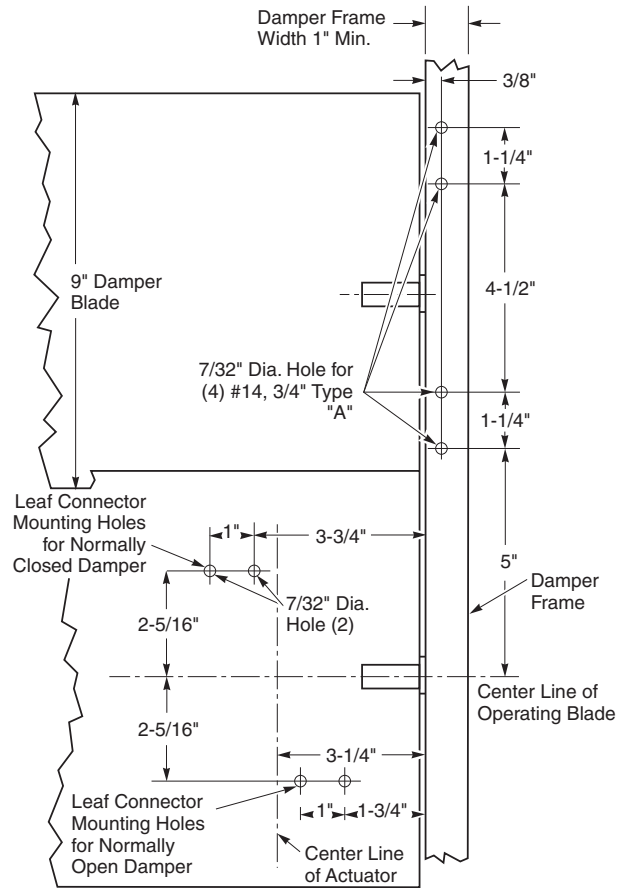

Figure-2 Mounting Dimensions for Bolt-on Bracket, and Leaf Connector.

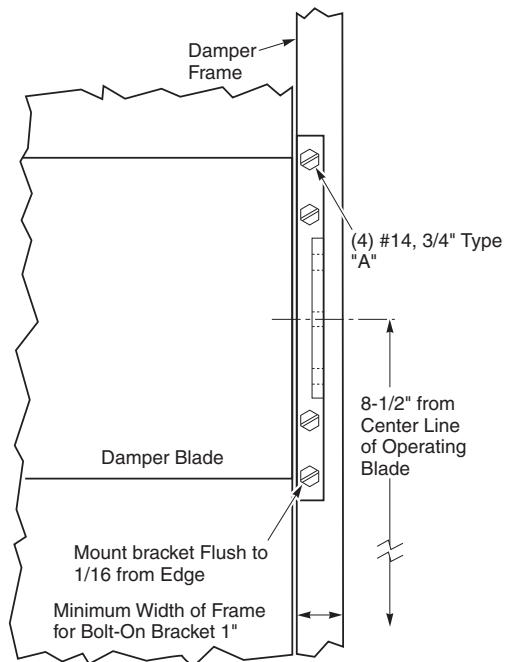

Figure-3 Typical Bolt-on Bracket Mounting.

Typical Frame Mountings

Damper Frame Mounting and Linking of Actuator

Requires frame AM-532 (bolt-on). Kit includes the frame bracket, leaf connector, and necessary screws or bolts and nuts for attaching the kit to the damper. (Refer to Figure-4 through Figure-7 for typical mounting locations.)

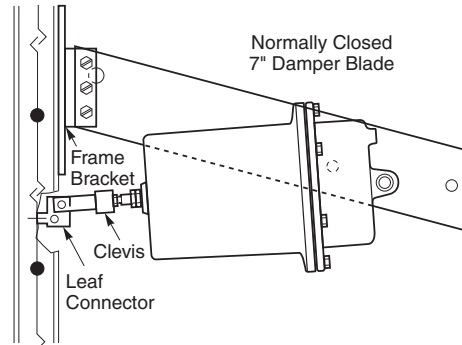

Figure-4 Normally Closed 7" Damper Blade.

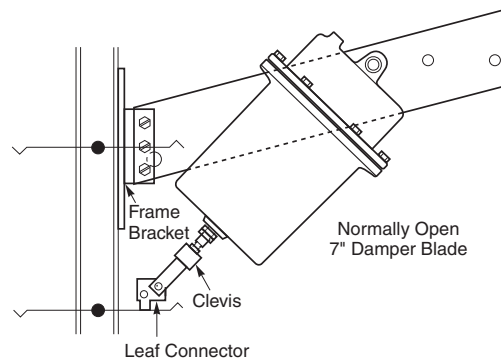

Figure-5 Normally Open 7" Damper Blade.

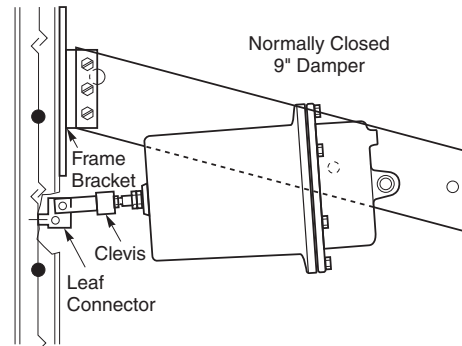

Figure-6 Normally Closed 9" Damper Blade.

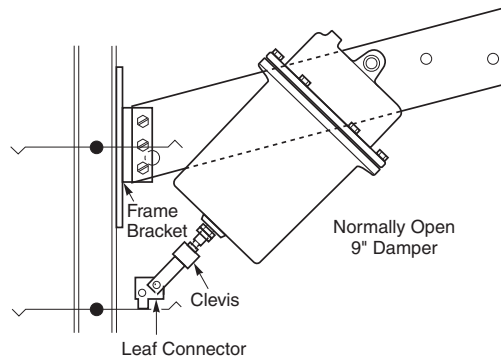

Figure-7 Normally Open 9" Damper Blade.

1. Drill necessary holes in damper for bolt-on bracket and leaf connector (see Figure-2). Dampers with blades 7 in. (180 mm) or smaller require notched cut in blade next to operating blade (see Figure-1).
2. Attach bolt-on (using four #14, 3/4 in. hexhead slotted screws) bracket to damper frame (see Figure-3).
3. Attach leaf connector using two 1/2 in. sets of nuts and bolts.
4. Remove actuator from its mounting plate.
5. Attach actuator mounting plate to frame bracket (using three 1/2 in. hexhead screws).
6. Reattach actuator to mounting plate.
7. Connect clevis to leaf connector. Clevis can be adjusted in order to align holes in clevis and leaf connector.

Actuator Mounting Brace Kit AM-538

To ensure smooth (non-jerky) operation of a damper (or other final control element), to prevent unnecessary cycling, and to prevent any type of binding actuator operation action (which may damage the actuator), the mounting means of each actuator must be rigidly secured to prevent any flexing movement as the actuator drives the final control element (damper, butterfly valve, etc.) through its full range of movement. It is sometimes necessary to devise special means to support the actuator rigidly. In many cases, the AM-538 brace kit can be used for this purpose (refer to Figure-8).

In cases where the AM-538 kit cannot be used, other means should be devised to support the actuator rigidly. For actuators mounted on a pivot rod (for example, a "post-mounted" actuator), the driven shaft of the final control element and the pivot rod must be kept parallel to each other to prevent binding. In some cases, an outboard bearing mounted near the crank-arm must be used to keep the driven shaft from flexing.

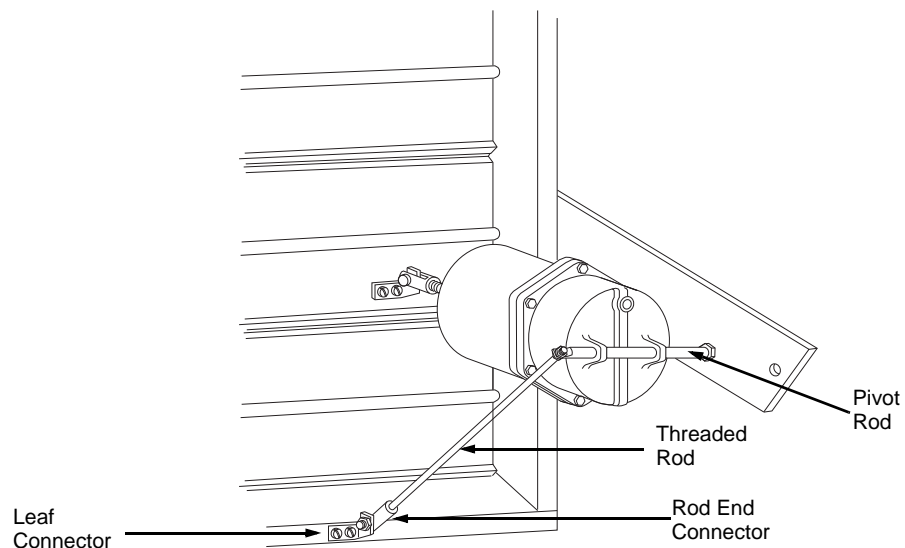

Figure-8 MK-7000 Series with Brace Kit.

1. Cut threaded rod to desired length.
2. Thread pivot rod end fitting to threaded rod.
3. Loosely assemble leaf connector to threaded rod end fitting.
4. Thread one nut to approximately 7 in. (180 mm) on the other end of threaded rod.
5. Slide threaded rod from damper side through pivot rod hole (pivot rod must be loosened from actuator bracket).
6. Locate leaf connector on edge of damper frame and mark position to drill mounting holes.
7. Drill two mounting holes 7/32 in. (6 mm) dia.
8. Mount leaf connector to damper frame.
9. Tighten nuts on threaded rod to actuator pivot rod.
10. Tighten pivot rod nuts to actuator mounting bracket.

External Mounting and Linking of Actuator Using AM-530 Crank Arm

Refer to Figure-9 and Figure-10.

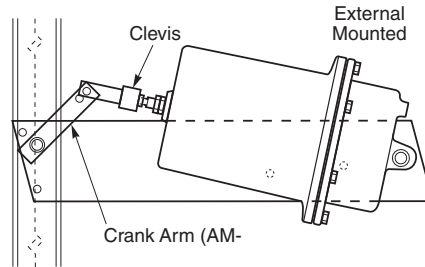

Figure-9 External Mounted Normally Closed.

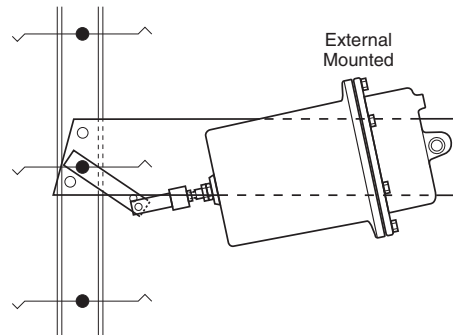

Figure-10 External Mounted Normally Open.

1. Remove actuator from its mounting plate.
2. Attach mounting plate to duct or wall with damper shaft protruding through location hole in mounting plate.
3. Attach actuator to mounting plate.
4. Loosely install crank arm (AM-530) to damper shaft at approximately 45° angle from perpendicular toward actuator.

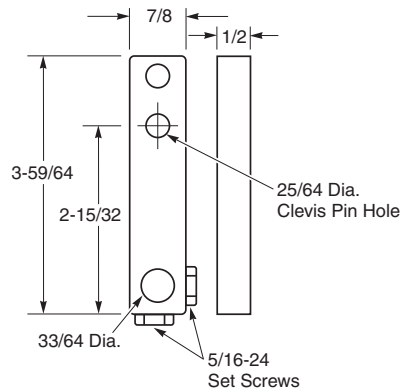

Figure-11 AM-530 Crank Arm.

5. Manually position damper to full retracted actuator position. Tighten crank arm in position described in Step 4.
6. Connect clevis to crank arm in farthest hole from damper shaft. Adjust clevis if necessary.

Connection of Air Line

Control air lines must be terminated at the actuator with at least 6 in. (150 mm) of flexible tubing allowing for pivoting of the actuator.

Caution:

When the MK2-71X1 actuator is used for high temperature applications, plastic tubing should not be used. A complete flexible loop of copper tubing should be used with brass compression fittings. The loop of copper tubing must be large enough and properly arranged so that actuator movement, from one extreme to the other, produces no strain on the tubing.

Floor Mounting and Linking of Actuator

Refer to Figure-12.

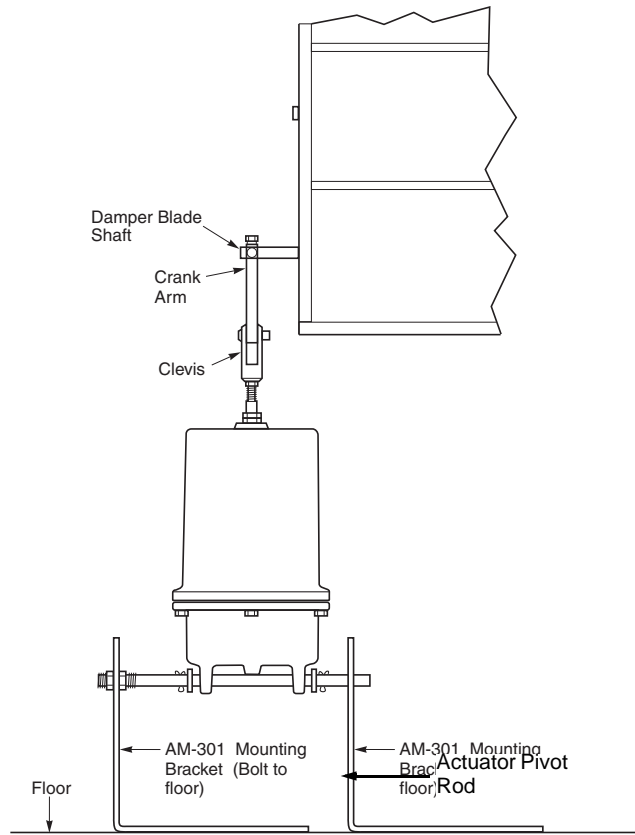

Figure-12 Typical Floor Mounting.

Requires AM-530 crank arm and AM-301 90° bracket.

1. Assemble crank arm to damper shaft extension.
2. Assemble actuator pivot rod 90° mounting bracket.
3. Position actuator and attach bracket to floor.
4. Link actuator to damper shaft.

Units with Factory Mounted Positive Positioners

Install fittings required in Ports P and M on positive positioner.

Adjustments

Refer to Figure-13.

Span Adjustment

The span is adjustable from 2 to 13 psig (14 to 90 kPa).

1. Insert the feedback spring into the adjustment slider.
2. Adjust the slider so that the spring is aligned with the required line on the scale.

Note: Span is the change of input pressure required to produce a full actuator stroke.

3. The scale is dimensional for a 4 in. (102 mm) actuator stroke. If the stroke length is other than 4in. (102 mm), calculate the adjustment slider position as follows:

$$\text{Adjustment Scale Position} = \frac{\text{Required Input Span} \times 4}{\text{Required Actuator Stroke Length}}$$

Start Point

The start point is adjustable from 1 to 12 psi (7 to 83 kPa). Start point is the pressure at which the actuator just begins to extend. See Figure-13 below.

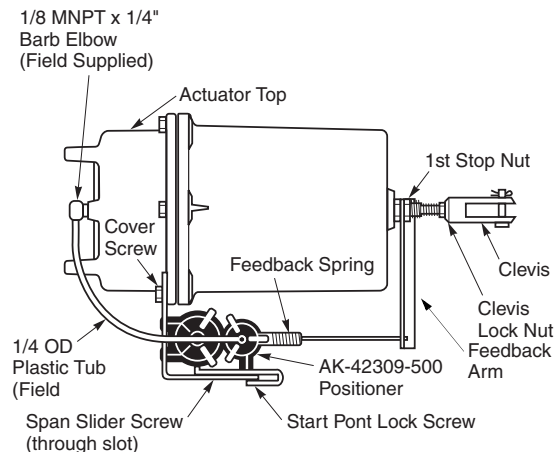

Figure-13 MK-7000 Series Actuator with AK-42309-500 Positioner.

1. Connect main air supply to Port M and a variable air supply to Port P.
2. Adjust variable air supply on Port P to desired start point pressure.
3. Loosen the start point lock screw with a small screwdriver.
4. Adjust the start point lever until the actuator just starts to extend.
5. Tighten the start point lock screw.
6. Remove variable air supply from Port P.
7. Connect Port P to controller output.

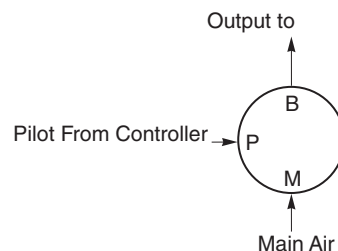

Figure-14 Typical Piping Diagram with Factory Mounted Positive Positioner.

Note: If slave damper actuators are to be controlled, tee into the tubing from Port B to the actuators. All dampers must be mechanically interconnected.

Field Mounting of Actuator with Positive Positioner

Field mounting of actuator with positive positioner is the same as for a factory mounted positive positioner. Refer to **AK-42309-500, Positive Positioning Pneumatic Relay General Instructions, F-22909**, for additional information.

CHECKOUT

After installation, the actuator should be checked to ensure proper damper operation. To check the actuator and linkage, proceed as follows:

1. Check the linkage with the actuator in the retracted position for proper return force. The actuator should be linked so that on a normally closed application, the damper is closed with no more than 1/16 in. (2 mm) compression of the spring. (The actuator shaft would return an additional 1/16 in. (2 mm) if the linkage were disconnected.) For a normally open application, the actuator should be linked with the actuator fully retracted.
2. Apply air pressure to the actuator or pilot port of a positioner and check the linkage as follows. On a normally closed application, the damper should be just full open when the actuator piston reaches the stop nuts in the actuator. On a normally open application, the damper should reach the closed position with no more than 1/16 in. (2 mm) stroke remaining to reach the actuator stop nuts.
3. The above can be obtained through adjustment of the clevis or by adjustment of the actuator stop nuts.

Adjustable Starting Pressure

Actuators are available with adjustable starting pressure. To adjust the starting pressure, turn stop nut on the actuator shaft clockwise to increase and counterclockwise to decrease the starting pressure. Each rotation of the stop nut changes the starting pressure 0.04 psi (0.28 kPa). See Figure-16.

Adjustable Stroke Length

Stroke length is determined by the two stop nuts on the actuator shaft. See Figure-16. Stops are set for 4-1/2 in. (114 mm) stroke. Turning stop nuts clockwise will shorten stroke length. Turning stop nuts counterclockwise will lengthen the stroke. Maximum stroke length is 5 in. (127 mm). By increasing the stroke length, the force available to resist an opposing force is decreased while decreasing the stroke length increases this force.

MAINTENANCE

Regular maintenance of the total system is recommended to assure optimum performance.

Diaphragm Replacement

See Figure-15.

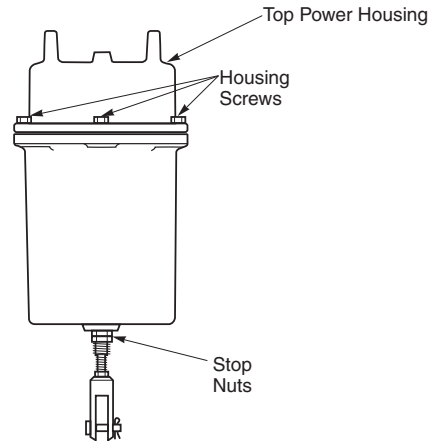

Figure-15 MK-7000 Series Housing Item Identification.

Caution:

Make certain the stop nuts are in place on the actuator shaft, otherwise the cup and shaft assembly, as well as the spring, may be released from the actuator.

1. Remove the six screws holding the top power housing.
2. Remove the top power housing and old diaphragm.
3. Roll the new diaphragm (PND-202) inside out and install over the piston. Make sure the circular bead is facing up.
4. Reinstall the top power housing making sure the bead on the diaphragm is in the housing groove and the screw holes are lined up.
5. Install and tighten housing screws.

DIMENSIONAL DATA

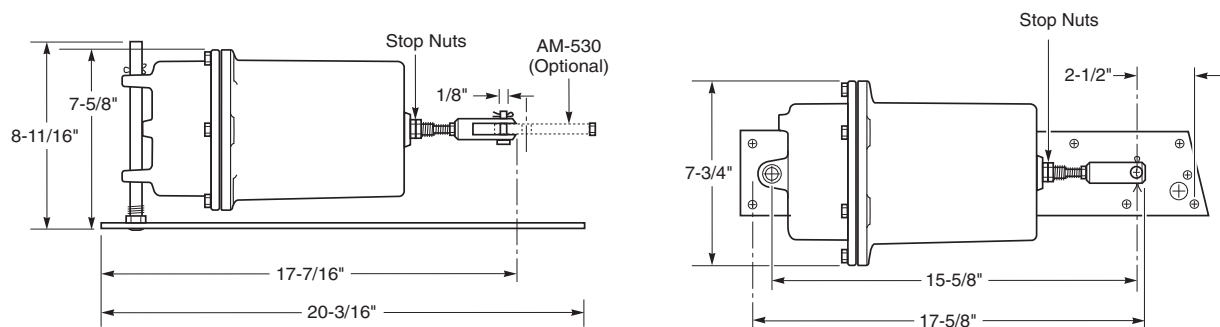

Figure-16 MK-7000 Series Actuator and Mounting Plate Dimensions.

Bracket Dimensions

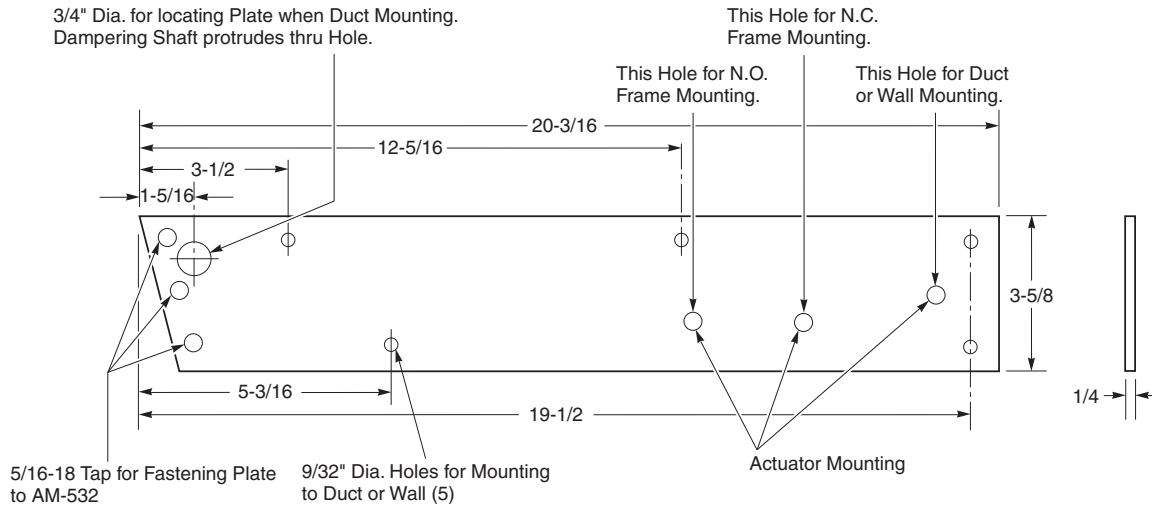

Figure-17 MK-7000 Series Mounting Plate.

Note:

The AM-538 kit includes leaf connector, and the required nuts, bolts, and screws.

The AM-542 kit includes the rod end connector.

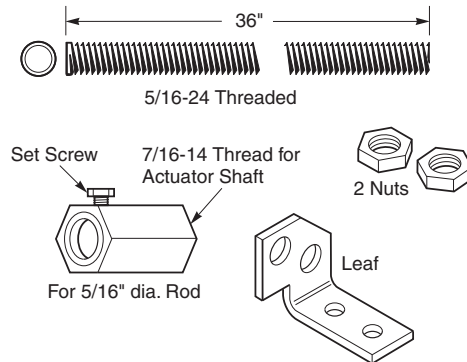

Figure-18 AM-538 and AM-542 Kits.

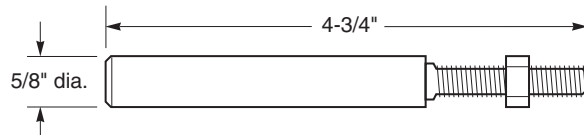

Figure-19 AM-543 Actuator Shaft Extension.

On October 1st, 2009, TAC became the Buildings business of its parent company Schneider Electric. This document reflects the visual identity of Schneider Electric, however there remains references to TAC as a corporate brand in the body copy. As each document is updated, the body copy will be changed to reflect appropriate corporate brand changes.