

Application

The MK-4800 series pneumatic valve actuator has an 11 in² (71 cm²) effective diaphragm area and is used to control 1-1/2" to 2" VB-9XXX series valves.

Features

- Rugged, die-cast aluminum housing
- 11 in² (71 cm²) effective area
- Replaceable, beaded, molded neoprene diaphragm

Applicable Literature

- Cross-Reference Guide F-23638
- Reference Manual F-21683
- Application Manual F-21335
- General Instructions Sheet F-23325, for Valve Linkage AV-420

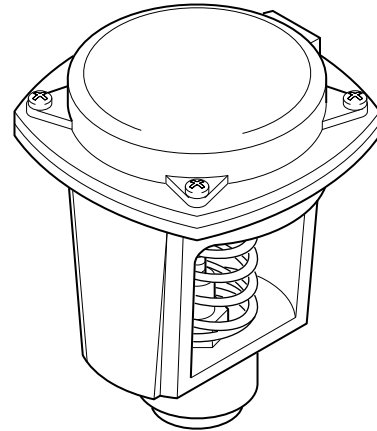

SPECIFICATIONS

Actuator Inputs

Compatible With: Proportional pneumatic signal. See Table-1.

Start Point, Adjustable ± 1 psi (7 kPa).

Air Connections: 1/8" FNPT, located on side of housing.

Actuator Outputs

Mechanical:

Stroke, 1" (25.4 cm) nominal.

Environment

Ambient Temperature Limits:

Shipping & Storage, -40 to 220°F (-40 to 104°C).

Operating, -20 to 220°F (-29 to 104°C).

Humidity: 5 to 95% RH, non-condensing.

Location: NEMA Type 1.

Maximum Air Pressure: 30 psig (207 kPa).

Spring: Retracts actuator shaft and raises valve stem on loss of air pressure.

Table-1 Spring Ranges.

Actuator Part Number	Nominal Spring Range* (Spring Color Code)	
	psig	kPa
MK-4801	3 to 8 (Black)	21 to 55
MK-4811	5 to 10 (Black)	34 to 69
MK-4821	8 to 13 (Blue)	55 to 90

* Nominal (no load) spring ranges based on 1" (25.4 mm) maximum stroke.

ACCESSORIES

AK-42309-500 Positive positioner and linkage

AV-420 Valve linkage

TOOLS

TOOL-95-1 Pneumatic calibration tool kit

MAINTENANCE PARTS

PNV-2 Diaphragm

PND-145-104 Replacement spring for MK-4801 and MK-4811

PND-145-107 Replacement spring for MK-4821

INSTALLATION

Inspection

Inspect the package for damage. If damaged, notify the appropriate carrier immediately. If undamaged, open the package and inspect the device for obvious damage. Return damaged products.

Requirements

- Piping diagrams
- Tools (not provided):
 - Appropriate screwdriver or wrench for field service
 - Appropriate pliers or equivalent to assemble the linkage kit
- Training: Installer must be a qualified, experienced technician
- Appropriate accessories and valve body

▼ **CAUTION**

- Disconnect the air supply before installation, to prevent equipment damage.
 - Make all connections in accordance with the piping diagram, and national and local codes.
 - Do not exceed the ratings of the device(s).
 - Avoid locations where excessive moisture, corrosive fumes, or vibration is present.
-

Valve Mounting

Mount the actuator on a valve so that it conforms to the following, as applicable:

1. Install all two-way valves so that they close against the flow. An arrow on the valve body or tag indicates proper flow direction.
2. Always install three-way mixing valves with two inlets and one outlet.
3. Always install three-way diverting valves with one inlet and two outlets.
4. Allow sufficient room above the actuator valve assembly for removal and reattachment of the actuator to the installed valve.
5. The valve actuator is generally mounted in an upright position, above the center line of the valve body. Do not mount the valve actuator below the center line of the valve.
6. The actuator may be swiveled, on a valve, to align the air connection with the control piping.
7. The actuator can be removed from the valve without disturbing the spring setting.
8. For steam applications only, position the valve body so the valve stem and actuator are at least at 45° from the vertical.

Assembly Instructions

For instructions on the installation of the actuator on a valve body, using the AV-420 valve linkage assembly, refer to the **AV-420 General Instructions F-23325**.

Disassembly Instructions

Actuator Removal from Valve Body

1. Remove the connecting pin to release the valve stem linkage from the actuator piston.

NOTE

To remove the connector pin, it may be necessary to relieve any binding by applying partial pressure to the actuator, to stroke it slightly.

2. Disconnect the control air line from the actuator.
3. Loosen the mounting nut (see Figure-1).

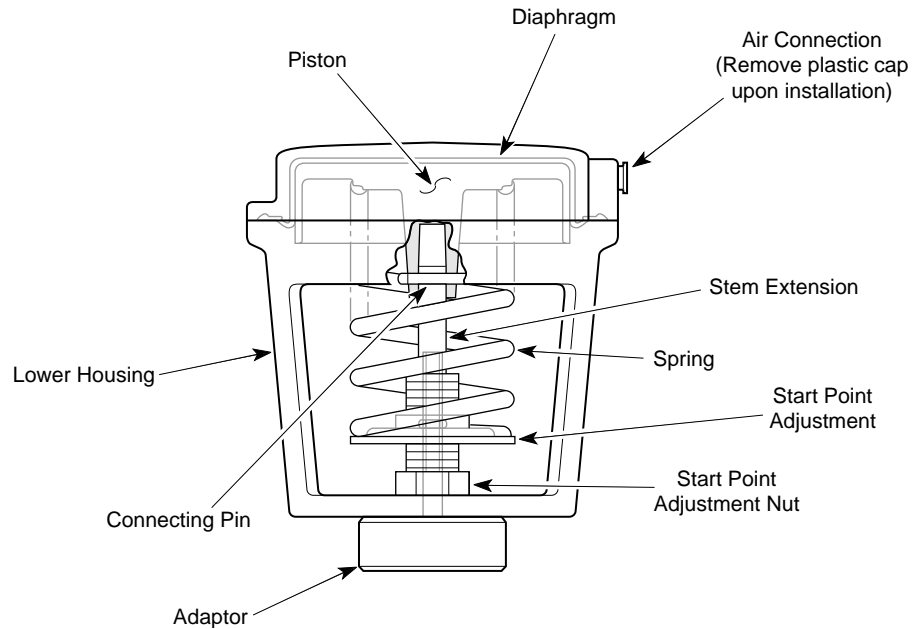

Figure-1 Actuator Parts Identification.

4. Rotate the actuator counterclockwise to unscrew it from the valve body.
5. Lift the actuator until it clears the valve stem linkage.

Adjustments

The start point adjustment is the only adjustment required on the actuator. The start point is the specific air pressure which, when applied to the actuator, causes the piston to just begin to move downward, under a no-load condition.

Whenever the diaphragm or spring is replaced, the start point may be changed. After replacing either of these parts, readjust the start point as follows:

1. Apply the desired start point air pressure to the actuator.
2. Rotate the start point adjustment nut in the appropriate direction until the desired start point is reached (see Figure-2):

To raise the start point, rotate the adjustment nut clockwise.

To lower the start point, rotate the adjustment nut counterclockwise.

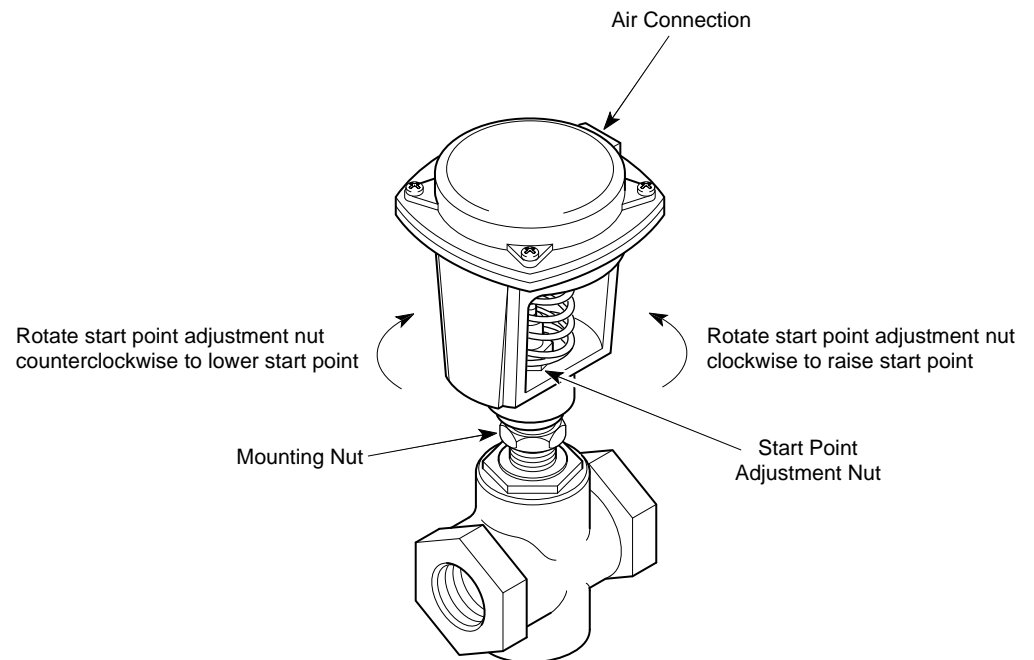

Figure-2 Actuator Start Point Adjustment.

MAINTENANCE

Regular maintenance of the total system is recommended to assure sustained, optimum performance.

FIELD REPAIR

Field repair is limited to the replacement of the actuator diaphragm or the actuator spring.

Actuator Diaphragm Replacement



▼ **WARNING**

The actuator must be connected to the valve body, and the piston must be connected to the valve stem when replacing the actuator diaphragm. Failure to do so may result in injury from high spring forces when removing the upper housing. These spring forces approach 100 lbs (45.3 kg).

1. Disconnect the control air line from the actuator.
2. Remove the four upper housing mounting screws, and remove the upper housing (see Figure-3).
3. Remove the old diaphragm.
4. Install the new diaphragm. Be sure the bead of the new diaphragm is properly positioned in the housing groove.
5. Reinstall the upper housing. Secure the upper housing in place with four screws, taking care to tighten them evenly.
6. Reconnect the control air line to the actuator.
7. Readjust the actuator start point, according to **Adjustments**.

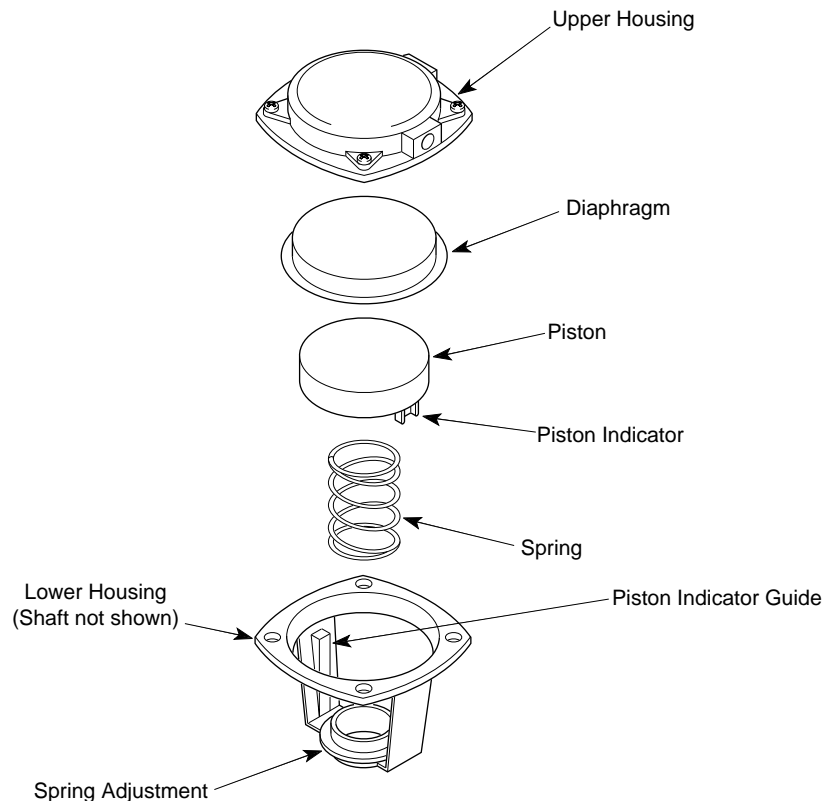

Figure-3 Field Repair of the Actuator.



Actuator Spring Replacement

▼ **WARNING**

The actuator contains spring forces approaching 100 lbs (45.3 kg). Incorrect disassembly of the actuator may result in injury from these high spring forces. Be sure to follow the proper disassembly procedure when replacing the actuator spring.

1. Disconnect the control air line from the actuator.
2. Rotate the start point adjustment nut fully counterclockwise, as viewed from the bottom of the actuator. This will reduce the spring compression as much as possible (see Figure-1).
3. Remove the four upper housing mounting screws, and remove the upper housing and the diaphragm (see Figure-3).
4. Apply downward pressure on the piston by hand, using the heel of the hand, and remove the connecting pin.
5. Remove the piston and the spring.
6. Install the new spring.
7. Reinstall the piston.
8. Apply downward pressure on the piston by hand, using the heel of the hand, and reinstall the connecting pin.
9. Reinstall the diaphragm. Be sure the bead of the new diaphragm is properly positioned in the housing groove.
10. Reinstall the upper housing. Secure the upper housing in place with four screws, taking care to tighten them evenly.
11. Reconnect the control air line to the actuator.
12. Readjust the actuator start point, according to **Adjustments**.

DIMENSIONAL DATA

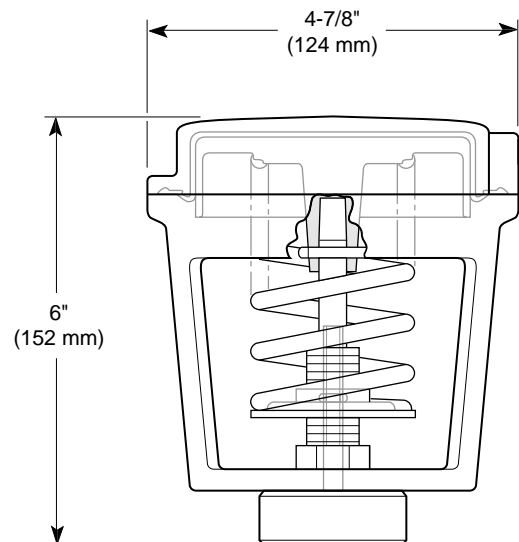

Figure-4 Actuator Assembly Dimensions.

On October 1st, 2009, TAC became the Buildings business of its parent company Schneider Electric. This document reflects the visual identity of Schneider Electric, however there remains references to TAC as a corporate brand in the body copy. As each document is updated, the body copy will be changed to reflect appropriate corporate brand changes.

Copyright 2010, Schneider Electric
All brand names, trademarks and registered
trademarks are the property of their respective
owners. Information contained within this
document is subject to change without notice.

Schneider Electric
1354 Clifford Avenue
P.O. Box 2940
Loves Park, IL 61132-2940

www.schneider-electric.com/buildings

