

Description and Application

These CSC-3000 series reset volume controllers are designed for use on heating or cooling systems with (normally open or normally closed) VAV terminal units and (direct or reverse acting) thermostats.

They are sub-master air velocity controllers. Each is equipped with separate adjustment knobs for minimum and maximum airflow setpoints. Models are available with various reset start points. A master controller, typically a room thermostat, resets the CSC-3000 between the minimum and maximum velocity setpoints.

The universal design of the CSC-3000 series is intended for new or replacement applications that call for direct or reverse acting reset on normally open or normally closed VAV terminal units.

*(These specifications do **not** apply to the CSC-3014 or CSC-3501/3505; see their separate Data Sheets.)

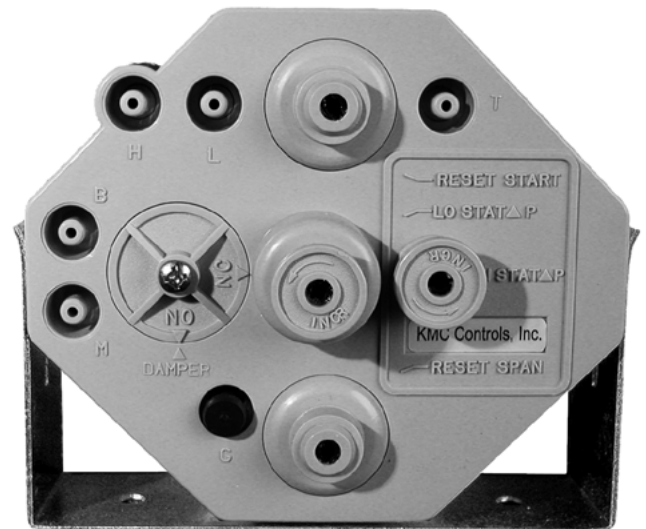

Models

NOTE: See the Model Selection Chart on the next page.

CSC-3011-10	0 to 1" range; 8 psig start
CSC-3016-10	0 to 2" range; 8 psig start
CSC-3017-16	(Identical to the CSC-3011-10 but does not come with a mounting bracket or KMC logo.)
CSC-3021-10	0 to 1" range; 3 psig start
CSC-3023-10	0 to 1" range; 10 psig start
CSC-3025-10	0 to 2" range; 8 psig start (high flow, for Trane® units)
CSC-3026-10	0 to 2" range; 3 psig start

NOTE: These CSC-3000 Series controllers are position sensitive. They must be mounted and calibrated in either the horizontal or vertical plane.

For the **CSC-3014** (designed to work with CTC-2100 Thermostats) and the **CSC-3501/3505** (Linear Volume Reset Controllers), **see their separate Data Sheets.**

Features

- ◆ Adjustable direct or reverse acting reset (normally open or normally closed damper settings)
- ◆ Adjustable minimum and maximum setpoints
- ◆ Available in 0 to 1" and 0 to 2" wc differential pressure ranges
- ◆ Available with factory-set 3, 8, or 10 psig reset start points (field-adjustable 0–10 psig if necessary)
- ◆ See the Specifications section for more details

Accessories/Repair Parts

HFO-0006	In-line control-air filter
HFO-0014	G port rubber cap replacement
HMO-4508	Mounting bracket
ICI-1005	Pressure gauge
SSS-1002	Flow sensor, one sensing point; 3-5/32" (80 mm) length
SSS-1003	Flow sensor, two sensing points; 5-13/32" (137 mm) length
SSS-1004	Flow sensor, three sensing points; 7-21/32" (195 mm) length
SSS-1005	Flow sensor, four sensing points; 9-29/32" (252 mm) length

Details

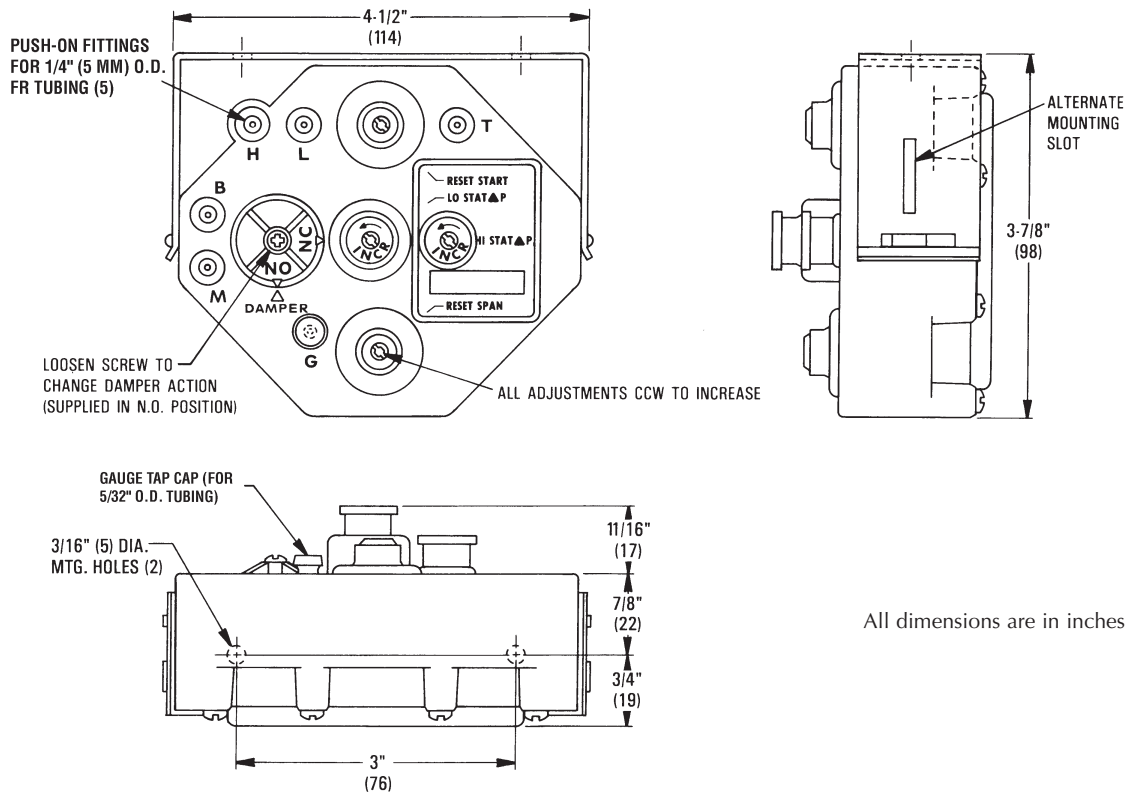

All dimensions are in inches (mm).

Specifications

Model Selection Chart

(*CSC-3017-16 is identical to the CSC-3011-10, but it does not come with a mounting bracket or the KMC logo)

Model #	Reset Start Point Factory Set (all field- adjustable 0–10 psig)	Differential Pressure	Min. Setpoint	Max. Setpoint	Output Sensitivity	Air Consumption
CSC-3011-10 CSC-3017-16*	8 psig (55 kPa)	0 to 1.0" wc (249 Pa)	0 to 1.0" wc (249 Pa)	Min. to 1.0" wc (249 Pa)	5 psi/0.02" wc (35 kPa/5 Pa)	28.8 scim @ 20 psig (7.87 mL/s @ 138 kPa)
CSC-3021-10	3 psig (21 kPa)					
CSC-3023-10	10 psig (69 kPa)					
CSC-3026-10	3 psig (21 kPa)					
CSC-3016-10	8 psig (55 kPa)	0 to 2.0" wc (498 Pa)	0 to 2.0" wc (498 Pa)	Min. to 2.0" wc (498 Pa)	5 psi/0.04" wc (35 kPa/10 Pa)	46.1 scim @ 20 psig (12.59 mL/s @ 138 kPa)
CSC-3025-10						

Damper Action Factory set @ NO, adjustable for NC or NO

Thermostat Action Direct or reverse action

Main Air Pressure 15 to 30 psig (103 to 207 kPa)

Max. Signal Pressure 6" wc (1493 Pa) applied to either port (H or L)

Reset Span Factory set @ 5 psig (35 kPa)

Temperature Limits

Operating 40° to 120° F (4° to 49° C)

Shipping –40° to 140° F (–40° to 60° C)

Material ABS

Weight 11 oz. (312 grams)

⚠ CAUTION

Pneumatic devices must be supplied with clean, dry control air. Any other medium (e.g., oil or moisture contamination) will cause the device to fail.

KMC Controls, Inc.

19476 Industrial Drive

New Paris, IN 46553

574.831.5250

www.kmccontrols.com; info@kmccontrols.com